



MEDALPOWER

Uninterruptible Power Supply(UPS)

120KVA

Online UPS

MP-OU120K3#48BC0K



www.medal-power.com

Foreword

Summaries

Thank you for choosing the UPS product!

This document gives a description of the UPS (120kVA) UPS, including the features, performance, appearance, structure, working principles, installation, operation and maintenance. etc.

Please save the manual after reading, in order to consult in the future.



NOTE



The figures in this manual are just for reference, for details please see the actual product.





Suitable Model

- 120K

Symbol Conventions

The manual quotes the safety symbols, these symbols used to prompt users to comply with safety matters during installation, operation and maintenance. Safety symbol meaning as follows.

Symbol	Description
 DANGER	Alerts you to a high risk hazard that could, if not avoided, result in serious injury or death.
 WARNING	Alerts you to a medium or low risk hazard that could, if not avoided, result in moderate or minor injury.

Symbol	Description
 CAUTION	Alerts you to a potentially hazardous situation that could, if not avoided, result in equipment damage, data loss, performance deterioration, or unanticipated results.
	Anti-static prompting.
	Be care electric shock prompting.
 TIP	Provides a tip that may help you solve a problem or save time.
 NOTE	Provides additional information to emphasize or supplement important points in the main text.

Contents

1	Safety Instructions	1
	1.1 Safety Announcements	1
	1.1.1 Safety Instructions	1
	1.1.2 Use Announcements for Battery	4
	1.1.3 Anti-Static Protection	5
	1.1.4 Grounding Requirements	5
	1.1.5 Safety Warning Label Setting	5
	1.1.6 Measure with Electricity	6
	1.2 Operation and Maintenance Requirements	6
	1.3 Environment Requirements	8
2	Overview.....	9
	2.1 Product Introduction.....	9
	2.1.1 Product Features.....	9
	2.2 Work Principle.....	11
	2.2.1 Work Principle Diagram.....	11
	2.2.2 Work Mode.....	11
	2.3 Appearance and Structure.....	12
	2.3.1 Appearance.....	12
	2.3.2 Structure Layout	15
	2.4 Optional Accessory	24
	2.4.1 SNMP Card and Its Software.....	24
	2.4.2 Expansion Cards	27
	2.4.3 Parallel/BCS System Accessory.....	30
	2.4.4 Battery Temperature Compensation.....	31

2.4.5 Surge Protection Device	31
2.4.6 Battery Release Control Accessory	31
2.5 Alarm Function.....	31
3 Installation.....	42
3.1 Installation Procedure.....	42
3.2 Installation Preparation	43
3.2.1 Installation Tools.....	43
3.2.2 Installation Environment.....	44
3.2.3 Installation Space	45
3.2.4 Selection for Input and Output Wires	46
3.3 Transportation and Unpacking	48
3.3.1 Transportation	48
3.3.2 Unpacking.....	49
3.4 Mechanical Installation	51
3.4.1 120K.....	51
3.4.3 Optional Accessory Installation	56
3.4.4 Battery Release Control Accessory Installation.....	58
3.4.5 Install Battery Cabinet	60
3.5 Wiring	61
3.5.1 60K, 80K, 100K, 120K.....	61
3.5.2 160K, 200K.....	64
3.6 System Check and Test.....	67
3.6.1 Check Electrical Connection.....	67
3.6.2 UPS Test	68
3.6.3 Connect Load.....	68
4 Touch Screen Operation and Setting	69
4.1 LCD Interface Flowchart	69
4.2 Main Page	70
4.3 System Work Status Display	71

Contents	User Manual
4.4 Buzzer Control Function	76
4.5 Monitor Page.....	76
4.5.1 Mains Input Information	76
4.5.2 Bypass Input Information.....	77
4.5.3 Battery Input Information	77
4.5.4 Rectifier Information	78
4.5.5 Inverter Information.....	79
4.5.6 Output Information	79
4.6 Setting Manage.....	80
4.6.1 Cabinet Setting.....	80
4.6.2 Battery Setting	81
4.6.3 Battery Test.....	81
4.6.4 Output Setting	81
4.6.5 Smart Mode.....	82
4.6.6 Dry Contact.....	82
4.6.7 Screen Setting	83
4.6.8 Password Setting.....	83
4.6.9 Communication Setting	84
4.6.10 Record Manage	84
4.7 Information Manage.....	85
4.7.1 Run Information.....	85
4.7.2 History Record	86
4.7.3 User Log	87
4.7.4 Smart Record	87
4.7.5 Smart Wave Capture.....	88
4.7.6 Device Information	88
4.8 ON/OFF	90
5 Use and Operation	92
5.1 Use Announcements.....	92
5.2 Operation Procedure.....	92
5.3 UPS Start and Shutdown	93

User Manual	Contents
5.3.1 Check before Startup.....	93
5.3.2 UPS Startup.....	93
5.3.3 UPS Shutdown.....	95
5.3.4 Switch to Bypass Mode Manually.....	96
5.3.5 Switch to Maintenance Bypass Mode From Inverter Output.....	96
5.3.6 Switch to Inverter Output from Maintenance Bypass.....	97
5.3.7 Emergency Power Off(EPO).....	98
5.3.8 Emergency Power Off Recovery.....	98
5.4 Parallel System Startup and Shutdown.....	99
5.4.1 Start Parallel System.....	99
5.4.2 Shutdown Parallel System.....	101
5.4.3 Emergency Power Off (EPO).....	102
6 Maintenance and Troubleshooting.....	103
6.1 Maintenance Guide.....	103
6.1.1 Safety Precautions.....	103
6.1.2 Preventive Maintenance.....	103
6.2 Battery Maintenance.....	104
6.3 Announcementsfor Battery Replacement.....	104
6.4 Troubleshooting.....	105
6.4.1 Common Abnormal Phenomena Diagnosis.....	105
6.4.2 Emergency Dispose for System Fault.....	107
7 Package, Transportation and Storage.....	108
7.1 Package.....	108
7.2 Transportation.....	108
7.3 Storage.....	108
A Technical Specifications.....	109
B Acronyms and Abbreviations.....	113

1 Safety Instructions

This chapter introduces the safety announcements. Prior to performing any work on the UPS, please read the user manual carefully to avoid human injury and device damage by irregular operations.

1.1 Safety Announcements

This section introduces the safety announcements that must be complied with and pay special attention while installing, using, maintenance and other relative operations.



CAUTION

Before operating, please read the announcements and operation instructions in this section carefully, which is to avoid accident.

The DANGER, WARNING, CAUTION in the manual are not all the safety announcements that you must abide by, they are just the supplements for the safety announcements during operating.



NOTE

Our Company does not undertake the responsibility caused by violating common safety operation requirements or the safety standard of design, manufacture and use.

1.1.1 Safety Instructions



CAUTION

The input and output of the UPS is dangerous high voltage, once operate improperly, it may endanger human safety. Please read this manual carefully before installing or operating, and pay attention to the warning labels. Do not dismantle the case of the UPS unless authorized person.

**DANGER**

It is prohibited to touching any terminal or conductor that connected with grid circuit, or, it may cause deadly danger.

**DANGER**

The damaged device or device fault may cause electric shock or firing!

- Before operating, please inspect the device and see if there is any damage or exist other danger.
 - Check if the external devices or circuit connection is safe.
-

**DANGER**

During a lightning storm, it is strictly prohibited to perform high voltage and AC operation, as well as in the tower or the mast. The atmosphere will generate a strong electromagnetic field in a lightning storm. Therefore, in order to avoid equipment struck by lightning, lightning protection and grounding system should be prepared in time.

**WARNING**

If the output load is impact feedback device, please consult the engineer of our company.

**WARNING**

Do not reversely connect the ground wire and neutral wire, live wire and neutral wire, which will cause short circuit.

It should be well grounded and the voltage between ground wire and neutral wire should be less than 5V.



WARNING

Please do not put finger or tool into rotating fans to avoid endanger the human safety or damage the device.



WARNING

In case of fire, please use dry power fire extinguisher. If using liquid fire extinguisher, it may cause electric shock.



CAUTION

The place where with good ventilation! Make sure front of air inlet, air outlet and fan of cabinet without blocking.



CAUTION

No liquid or other objects are allowed to enter the cabinet.



CAUTION

The product is class C3 device. If the product is used in resident living, it may cause wireless interference. User should take actions to avoid the interference.

**CAUTION**

Warning label should be affixed away from UPS location!

When UPS is power off, there still exists dangerous voltage. It should affix warning labels away from UPS location and the warning labels should include: 1. It supplies power for UPS. 2. Please disconnect UPS before wiring.

1.1.2 Use Announcements for Battery

**CAUTION**

Please use specified battery. Non-specified battery will damage the UPS.

The charging voltage of different brand and different model battery is different. Before using, ensure that the charging voltage of the UPS matches that of battery. If doubted, please consult the manufacturer for support.

**WARNING**

Battery operation must be done according to instructions!

Battery operation must be done according to instructions, especially battery wiring. Irregular operation will cause battery damage, even human injury.

- It is prohibited to short circuit the anode and cathode of the battery. The battery wiring must be tightened. It is strictly prohibited to touch any two wiring terminals of battery or the bare terminals of wires simultaneously, or it may cause battery damage or human injury.
 - Prevent electrolyte leaking from batteries. The metal objects and circuit board will be corroded by the overflowing electrolyte and it will result in equipment damage and circuit board short circuit.
 - Keep the battery away from fire source and all device that easy cause spark to avoid danger or unnecessary lose.
-

1.1.3 Anti-Static Protection



CAUTION

The static generated by human bodies may damage the electrostatic-sensitive components on PCB. Before touching the sensitive component, please wear anti-static rings and well connect the other end of the anti-static rings to ground.

1.1.4 Grounding Requirements



WARNING

High leakage risk! The device must be grounded before electrical connection. The grounding terminal must be connected to earth.

- When installing, connect the grounding wire first; when dismantling, the grounding wire must be removed at last.
- It is prohibited to damage the grounding conductor.
- The device must be connected with protection earthing permanently. Before operating, please check the electric connection and ensure the device has been connected to earth reliably.

1.1.5 Safety Warning Label Setting

To avoid irrelevant person close to or misoperate the UPS, during installation or daily maintenance, please comply with the related standards.

- Set warning labels at the switches of input end and output end to avoid wrongly close and even cause accident.
- Set warning label or safety warning area to avoid irrelevant person entering and cause human injury or device damage.
- After maintenance, ensure that pull out the key of the UPS and save it properly.

1.1.6 Measure with Electricity



CAUTION

There is dangerous high voltage, contacting by accident may lead to deadly danger. So, when measure with electricity, it is necessary to do the protection (such as wear insulated gloves, etc.)

The measure meter must accord with the following requirements.

- The range and use condition of the measure meter should conform to the site requirements.
- Ensure that connection of the measure meter is proper and normative, which is to avoid the danger of electric arc, etc.

1.2 Operation and Maintenance Requirements

There exists high temperature and high voltage inside the UPS. Please comply with the relevant safety regulations and operation procedures during installation, operation and maintenance to avoid human injury or device damage. The safety precautions mentioned in the user manual is just as a supplement to the local safety regulations. Our company does not undertake the responsibility caused by violating the common safety operation requirements or safety standards for design, manufacture and use the device.



CAUTION

The related operation and wiring for the UPS should be performed by qualified professionals, and ensure the electric installation accord with the electricity installation standards.

The installation and maintenance man should be trained and know each safety announcements and get the right operation method, and then, the installation, operation and maintenance can be done.



DANGER

Mounting and dismantling power cables is prohibited when power on. Please switch off the power switches before mounting or dismantling power cables. Before connecting, make sure the cable connection, cable labels are in accordance with the actual installation.

**WARNING**

Touching high voltage directly or through damp objects will lead to lethal risk.

- Only authorized professionals are allowed to open the UPS chassis! The input and output of UPS are dangerous high voltage. Touching high voltage will lead to lethal risk.
- Before maintenance, please disconnect the AC power and battery to isolate the power input. It is better to measure the input, output and battery terminal bars by a voltmeter to ensure the input power is disconnected and in a safe condition.
- Even if all external power are disconnected, there still exists residual electric charge on the capacitance inside the UPS, and the output terminal bars may exist high voltage which endangers human life. It is necessary to set the UPS aside for enough time (≥ 10 min) to release all charge before opening the UPS chassis.
- The battery cables are not isolated with AC input. There may exist dangerous voltage between battery terminal and grounding terminal. Pay attention to the insulation when installing and using the battery.
- Do not wear conductive objects, such as watches, bracelets and rings during operating.
- The installing man should have the qualification of high voltage and AC power operation. The maintenance and repair for the power system only can be done by professional persons.
- Leakage risk! Before performing electrical connection, the UPS should be grounded. The ground terminal must be connected to the ground.

**WARNING**

Drilling holes on the cabinet is prohibited! Inappropriate drilling will damage the components inside the UPS. Metal debris generated by drilling will lead to circuit board short circuit.

**NOTE**

Changing the UPS configuration, structure or assembly will affect the performance of the UPS. If user needs to do like this, please consult the manufacturer in advance.

1.3 Environment Requirements

The used environment may influence the service life and reliability of the device. So, please avoid using the device in the following environment for long time.

- The place where beyond the specification (normal work temperature: $-5^{\circ}\text{C} \sim 40^{\circ}\text{C}$, relative humidity: 0%-95%).
- The place where has direct sunshine and rain.
- The place where has vibration or easy impacted.
- The place where has dust, corrosive material, salty or flammable gas.
- The place where without good ventilation or closed.

2 Overview

This chapter mainly introduces the use scope, product feature, work principle and modes, appearance and layout, alarm list etc. of the UPS.

2.1 Product Introduction

This series product is the high-frequency online double-conversion UPS. It is the high performance sine-wave UPS that special designed for the network computer room, precision instrument, etc. of financial, communication, insurance, transportation, tax, army, security, energy, education, government, enterprise, etc.

2.1.1 Product Features

Three-level inversion technology

Adopts three-level inversion technology, which makes the quality of output voltage wave better and the efficiency of whole UPS higher.

Completely digitalized DSP control

Adopts digitalized DSP to control the inverting, phase synchronization, output current-sharing, logic of the power unit, which is with high precision, high speed and perfect whole system performance.

Energy conservation and high efficiency

Adopts advanced PFC control technology, the input power factor is greater than 0.99, which greatly improves the use ratio of electric energy and reduces the load of power grid, and save the cost of power distribution. The size of whole UPS is small, and the weight is light, calorific value is small, which enhances the use ratio of environment and decrease the investment cost.

Smart fan speed control

The fan speed is adjusted automatically in accordance with the load status, which prolong fan life and reduce noise.

ECO energy conservation mode design

The UPS is designed with ECO energy conservation mode. When the user power grid is good, if the UPS operating in this mode, the bypass prior to output, and the efficiency can be 99%.When the bypass voltage or frequency out of normal range and cannot satisfy the user's power supply requirement, it will switch to inverter output, and this guarantee the reliability of power supply and also, save energy.

Manual maintenance bypass design

It designs manual maintenance bypass channel to ensure the UPS supply power for load while maintenance, which greatly improve the system operation reliability and maintainability.

Reliable EMC performance

Pass the authority institution and professional test on EMC, including conducting disturbance, radioactive disturbance, conducting anti-disturbance, radioactive anti-disturbance, power falling, mass impulse, static discharging, surge, etc. The excellent EMC characteristics can completely filter each power grid interference, and also, decrease and eliminate the interference of UPS itself effectively.

Touch screen display

With touch screen display, the operation is simple and convenient, which is convenient to daily manage and maintain the UPS. It can display the running parameters and running status of UPS and each power unit, and record the history event and alarm information. It can store 10000 pieces of information at most.

2.2 Work Principle

2.2.1 Work Principle Diagram

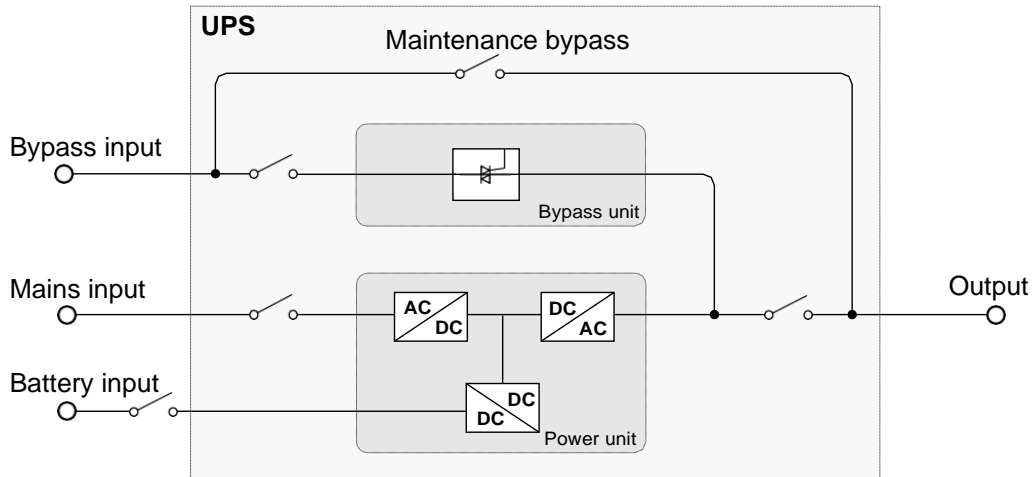

Figure2-1 Work principle diagram

2.2.2 Work Mode

There are 4 work modes of the UPS: normal mains mode, battery mode, bypass mode and maintenance bypass mode.

Normal mains mode

When the mains normal, AC power is transformed to DC power by PFC, and supply power for inverter. While rectifying the AC power into DC power, the rectifier eliminates the abnormal noise wave, noise and unstable frequency, and make the inverter provide stable and clean power for load. The specific work process is as follows.

When mains normal, the inverter inside the power unit rectify the mains into anode and cathode DC voltage. the DC voltage output stable 220Vac voltage to load after it through inverter. When the system control card detects the inverter normal, it will supply the inverting voltage to load.

Battery mode

When mains abnormal, system will switch to battery input, the Boost circuit promotes the battery voltage to a certain value and then supply the DC power to the inverter, that makes the AC output without interruption phenomenon and then protect the load. The specific work process is as follows.

When mains abnormal at any time, the rectifier will switch to battery input immediately to maintain the voltage of DC electrolysis, which guarantee the inverter without power down. Before battery discharge completely, if mains recovers, the rectifier will switch to mains input and charge battery at

the same time. During the switch between grid power supply and battery power supply, the inverter output cannot power down.

In battery power supply mode, if mains does not recover normal all the time, and the battery energy is running out, the UPS will send sound & light alarm, and stop working at the max. discharge point, and long beeps to alarm. At that time, the load will power down.

Bypass mode

When system abnormal (such as over-temperature, short-circuit, output voltage abnormal or overload) and exceed the bear range, the inverter will shut down to avoid damage automatically. If mains still normal at this time, it will turn to bypass to supply power for load. The specific work process is as follows.

If the inverter circuit fault or inverter overload and exceed the bear range, the UPS will turn to bypass to output. During bypass power supply, if fault or overload removed, the UPS will start inverter and begin to supply power for load. When the load is serious overload and exceeds the bypass bear range, the UPS will close the bypass output, and it will cause user load power down. When load fault or short circuit, the UPS will switch to bypass to supply power from inverter. If the short-circuit is serious, the UPS input switch and bypass switch may trip out. After suffering the short-circuit fault, UPS will try to restart. If the short-circuit is removed, the UPS will switch to inverter; if the fault is not removed, the UPS will try to restart for 3 times. 3 times later, the UPS will turn to fault protection. At this time, it needs to power off or press the touch screen to shut down the UPS, and restart the UPS, and then, it will recover normal work.

Maintenance bypass mode

When the UPS needs to be maintained and the power supply for load cannot be interrupted, user can shut down the inverter and make the UPS works in bypass status, then switch on the maintenance bypass switch and switch off the mains input switch, bypass power supply switch and output switch. During the transforming of manual maintenance bypass, AC power is supplied for load by maintenance bypass switch. At this time, the inner UPS has no electricity, maintainer can perform the maintenance safely.

2.3 Appearance and Structure

2.3.1 Appearance

The appearance of this series UPS is as shown in Figure2-2, Figure2-3.



Figure2-2 Appearance of 120K

Operation panel

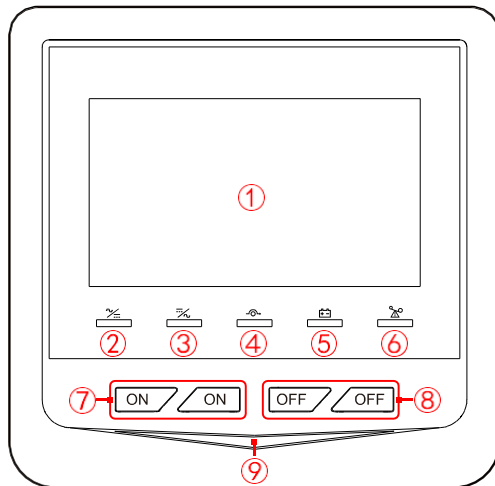





Figure2-4 Operation panel of 120K

Table2-1 Illustration for the operation panel

No.	Sill-screen	Name	Illustration
①	-	Touch screen	Shows the running parameters (such as voltage, current, load, etc.) and status
②		AC/DC indicator	On (green): rectifier works normally. On (red): rectifier abnormal.
③		DC/AC indicator	On (green): inverter works normally. On (red): inverter abnormal.
④		BYP. indicator	On (green): bypass output. On (red): bypass abnormal.
⑤		BATT. LOW indicator	On (green): battery mode. On (red): battery is low-voltage.
⑥		OVERLOAD indicator	On (green): output normally. On (red): output is overload.
⑦	ON	“ON” combination button	Press the two buttons for 3s, the system will power on.
⑧	OFF	“OFF” combination button	Press the two buttons for 3s, the system will power off.
⑨	-	Atmosphere lamp	On (blue): UPS works normally. Flicker(blue): battery mode. On (yellow): UPS abnormal but works normally. On (red): UPS abnormal and cannot works.

2.3.2 Structure Layout

The structure layout of this series UPS is as shown in Figure2-6, Figure2-7, corresponding devices illustration as shown in Table2-2.

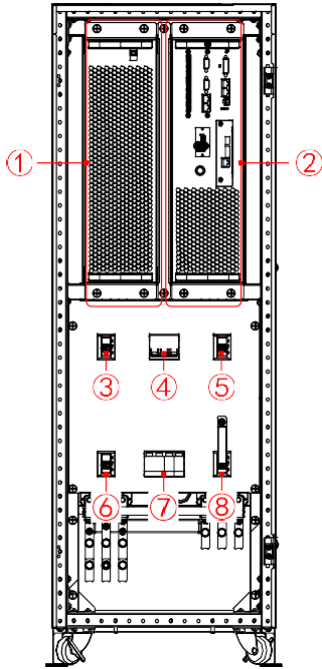

Figure2-6 Structure layout diagram of 120K(open the door)



NOTE

The specifications of main switch, output switch, bypass switch and maintenance bypass switch of 100K, 120K, 80K, and 60K are different a bit. The above figure take 60K as example to illustration, for details please see the actual product.

Table2-2 Structure illustration

NO.	Name	NO.	Name
①	Power unit	⑤	Output switch
②	Bypass unit	⑥	Bypass switch
③	Mains switch	⑦	SPD(optional)
④	SPD switch(optional)	⑧	Maintenance bypass switch

Power unit

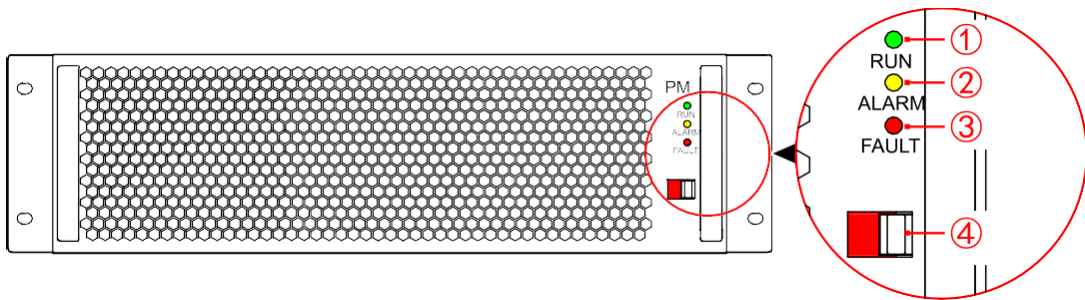

Figure2-8 Power unit

Table2-3 Power unit illustration

NO.	Skill-screen	Name	Illustration
①	RUN	Run indicator	On (green): running normally.
②	ALARM	Alarm indicator	On (yellow): alarm.
③	FAULT	Fault indicator	On (red): fault.
④	-	Limit switch	On (red): running. On (green): exit.

Bypass unit

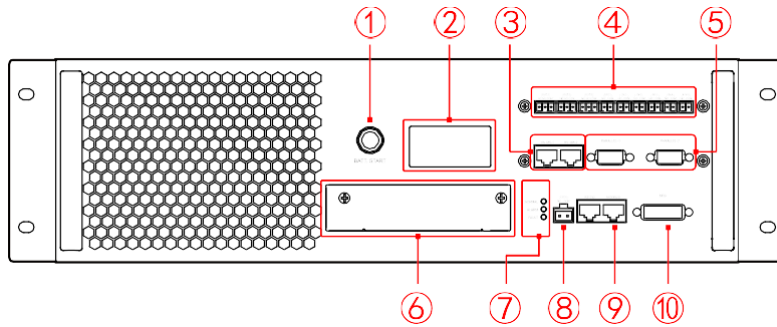

Figure2-9 Bypass unit

Table2-4 Bypass unit illustration

NO.	Name	Illustration
①	BATT. start button	Battery cool start function.
②	SNMP card slot	Optional SNMP card, for details please see 2.4.1 SNMP Card and Its Software .
③	RS485 port	It is used for a machine to monitor the running information of other parallel systems. RS485 port adopts RJ45 plug. The pin definition of RS485 port as shown in Figure2-10. In parallel system, the RS485 connection are as shown in Figure2-11 and Figure2-12.
④	Dry contact port	Illustration see Table2-5, corresponding dry contact see Table2-6, Table2-7.
⑤	PARALLEL port	Parallel wires are for parallel ports connection between cabinets. When multi UPSs in parallel, connect the parallel port of each UPS by parallel wire. N UPSs require N parallel wires to ensure there are at least two parallel wires for a UPS, which will improve parallel reliability.
⑥	Expansion card slot	Optional BMS expansion card and dry contact expansion card, for details please see 2.4.2 Expansion Cards .
⑦	Indicator	NORMAL (green) On: system control card in primary card running status. Flicker: system control card in initialization status.

NO.	Name	Illustration
	ALARM (yellow)	On: system control card have alarm signal.
	FAULT (red)	On: system control card fault.
⑧	EPO2 input dry contact	Normal close input port of external EPO. The signal is valid when NC terminal and COM terminal disconnect. The signal is preset and cannot settable.
⑨	MODBUS port and RS232 port	Communication protocol support MODBUS RTU or Kehua standard serial port protocol, switch it by touch screen. MODBUS/RS232 port adopts RJ45 plug to connect, the Pin definition as shown in Figure2-13, Figure2-14.
⑩	MDU port	Touch screen communication port.

• RS485 port

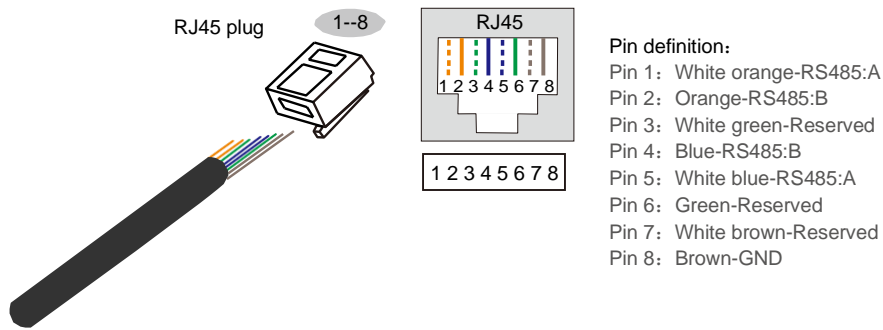

Figure2-10 Pin definition of RS485

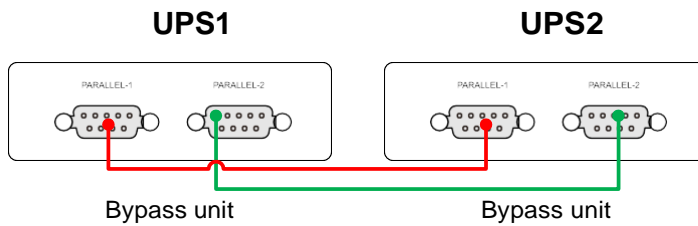

Figure2-11 RS485 port wiring(Two UPSs)

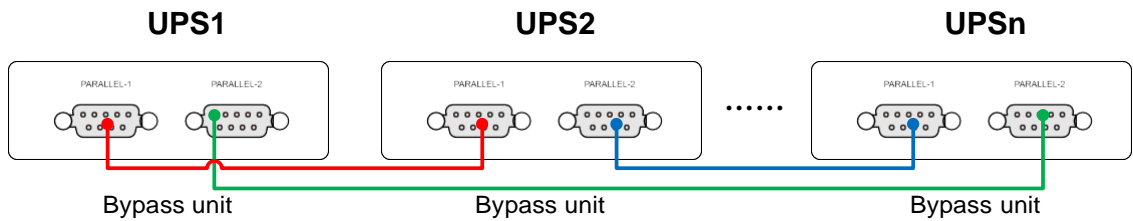

Figure2-12 RS485 port wiring(Multiple UPSs)



NOTE

Wiring color in Figure2-11 and Figure2-12 just for display only, it cannot stands for the actual wire color, for specific color please see the actual wire.

- Network port: MODBUS port and RS232 port
1. MODBUS port is used for MODBUS serial port communication, which is to communicate with upper computer. MODBUS port adopts RJ45 plug. The pin definition as shown in Figure2-13.

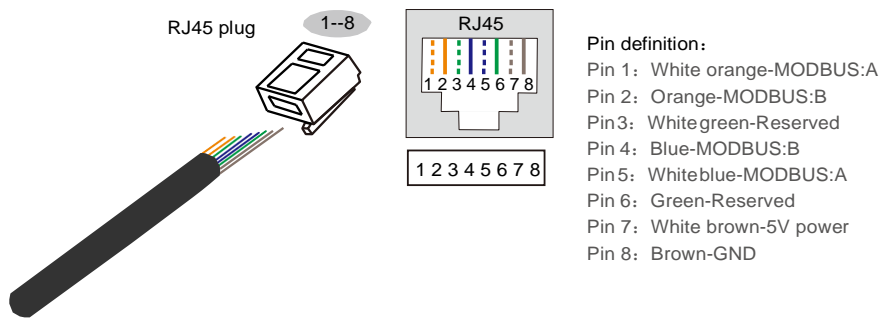

Figure2-13 Pin definition of MODBUS

2. RS232 port is used for RS232 serial port communication, which is to achieve the external SNMP card communication. RS232 port adopts RJ45 plug. The pin definition as shown in Figure2-14

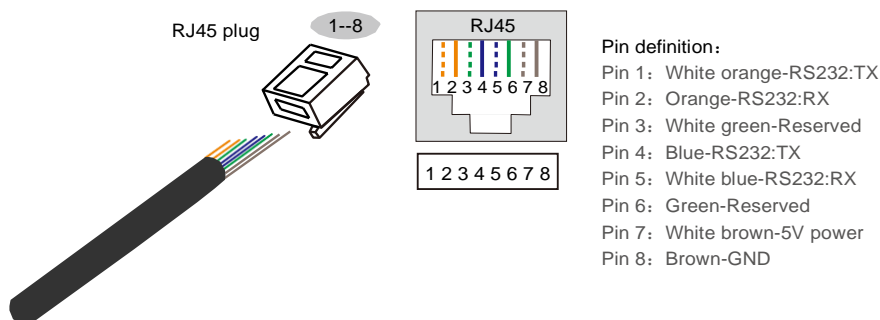

Figure2-14 Pin definition of RS232

- Dry contact port

Table2-5 Dry contact illustration

Port	Skill-screen	Signal	Function illustration
EPO1	NO	External EPO normal open port	When the NO and COM is short circuit, the signal is effective. The signal is preset and isn't settable.
	COM	Reinforced insulation ground	
B-Temp	NC	Battery temperature sampling resistance port	External temperature sampling wire. The signal is preset and isn't settable.
	COM	Reinforced insulation ground	
EPO2	NC	External EPO normal close port	When the NC and COM disconnect, the signal is effective. The signal is preset and isn't settable. (Recommend to use EPO1 NO dry contact. If user want to use EPO2 NC dry contact, please contact the service before use it.)
	COM	Reinforced insulation ground	
OUT.1	NC	OUT.1 normal close output port	When the signal is effective, COM and NO connect, and NC disconnects. This signal is settable, as shown in Table2-7.
	COM	Reinforced insulation ground	
	NO	OUT.1 normal open output port	
OUT.2	NC	OUT.2 normal close output port	When the signal is effective, COM and NO connect, and NC disconnects. This signal is settable, as shown in Table2-7.
	COM	Reinforced insulation ground	
	NO	OUT.2 normal open output port	
OUT.3	NC	OUT.3 normal close output port	When the signal is effective, COM and NO connect, and NC disconnects. This signal is settable, as shown in Table2-7.
	COM	Reinforced insulation ground	
	NO	OUT.3 normal open output port	
IN.1	NO	External switch normal open input port	When the NO and COM is short circuit, the signal is effective. This signal is settable, as shown in Table2-6.
	COM	Reinforced insulation ground	

Port	Skill-screen	Signal	Function illustration
IN.2	NO	External switch normal open input port	When the NO and COM is short circuit, the signal is effective.
	COM	Reinforced insulation ground	This signal is settable, as shown in Table2-6.
IN.3	NO	External switch normal open input port	When the NO and COM is short circuit, the signal is effective.
	COM	Reinforced insulation ground	This signal is settable, as shown in Table2-6.
IN.4	NO	External switch normal open input port	When the NO and COM is short circuit, the signal is effective.
	COM	Reinforced insulation ground	This signal is settable, as shown in Table2-6.

The input port(IN port) card can be defined (10 types dry contact definition as shown in the Table2-6) according to user requirements.

Table2-6 Input dry contact definition

NO.	Dry contact definition	Remarks
1	Battery abnormal	When this signal is received, UPS alarms and records this status, and then turn off charge function.
2	Battery grounding abnormal	Grounding abnormal signal
3	Battery switch disconnect	Battery circuit switch auxiliary contact mark.
4	Bypass switch disconnect	Bypass switch auxiliary contact mark.
5	Output switch disconnect	Output switch auxiliary contact mark.
6	Battery discharge disable	Battery discharge disable mark.
7	Battery charge disable	Battery charge disable mark
8	Generator mode	Co-ordinate with the auto generator mode, start the generator mode.
9	SPD abnormal	UPS record that the SPD abnormal.

NO.	Dry contact definition	Remarks
10	Maintenance bypass start	Start maintenance bypass mark.

The output port(OUT port) card can be defined(18 types dry contact definition as shown in the Table2-7) according to user requirements.

Table2-7 Output dry contact definition

NO.	Dry contact definition	Remarks
1	Inverter output	UPS is in the inverter output status, and this dry contact is ON.
2	Bypass output	UPS is in the bypass output status, and this dry contact is ON.
3	Battery trips	Battery trips, and this dry contact is ON.
4	Battery output	UPS is in the battery power supply status, and this dry contact is ON.
5	Battery under-voltage alarm	Battery discharges to the under-voltage alarm, and this dry contact is ON.
6	Battery under-voltage protection	Battery discharges to the under-voltage protection status, and this dry contact is ON.
7	Output overload	UPS is in the overload status, and this dry contact is ON.
8	UPS abnormal	Abnormal status, and this dry contact is ON.
9	Bypass abnormal	Bypass is abnormal or it's unable to track bypass, and this dry contact is ON.
10	Mains abnormal	Mains is abnormal, and this dry contact is ON.
11	Start generator	When the generator starts, and this dry contact is ON.
12	ECO output	UPS is in the ECO output status, and this dry contact is ON.

NO.	Dry contact definition	Remarks
13	Inverter abnormal	When the UPS inverter is abnormal, and this dry contact is ON.
14	Single bypass feedback	When detect single bypass feedback, and this dry contact is ON.
15	Parallel bypass feedback	When detect parallel bypass feedback, and this dry contact is ON.
16	UPS power on	When the UPS in power on status, and this dry contact is ON.
17	Fan abnormal	When the fan of UPS is abnormal, and this dry contact is ON.
18	UPS alarm	When the UPS alarm, and this dry contact is ON.

**NOTE**

Get dry contact function of single bypass feedback and parallel bypass feedback in Table2-7 by customization.

**CAUTION**

The dry contact port cannot connect with dangerous signal which may damage device or personal safety, it should connect to SELV circuit after isolation.

2.4 Optional Accessory

The series UPS can be equipped with different accessories to meet the needs of different users.

2.4.1 SNMP Card and Its Software

SNMP card(as shown in Figure2-15) is installed in the UPS to realize the UPS remote management.

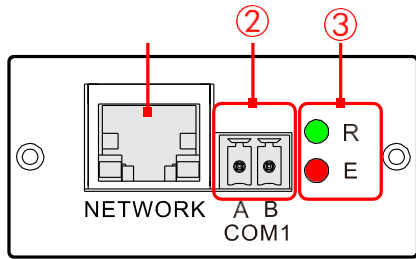

Figure2-15 SNMP card

NOTE

When the SNMP card is selected, the SNMP card will be installed on the bypass unit of UPS.

Table2-8 Illustration of SNMP card

NO.	Name	Function description	
①	NETWORK port	Ethernet port	
②	COM1 port	Connect with humiture unit(RS485)	
③	Indicator	R	Show working status, details as shown in Table2-9.
		E	

- NETWORK port

NETWORK port adopts RJ45 plug. The pin definition of the NETWORK port as shown in Figure2-16.

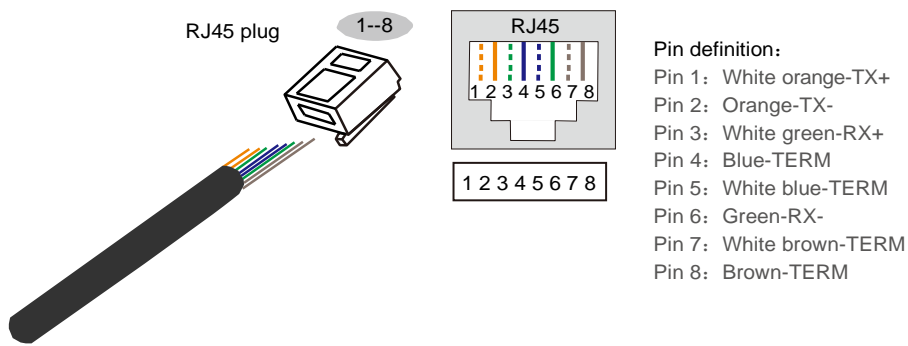

Figure2-16 Pin definition of NETWORK port

- Indicator status

Table2-9 Illustration of indicator of the SNMP card

Green indicator (R)	Red indicator (E)	Status description
ON	ON	Start
Flicker	*	Running
OFF/ON	*	Crash, keep final status
*	OFF	NO alarm
*	Flicker	Alarm

**NOTE**

* means the indicator is in any status.

SNMP card software

**NOTE**

It is suitable but not only for the following browsers(the early operating system may not be good in compatibility): Chrome56+ browser, IE11+ browser. The login interface is different in different browser, using the screen resolution of computer better than 1600*900.

**CAUTION**

Please ensure that the setting IP address is in the same network segment with user's computer IP address.

After finishing the SNMP installation and wiring, please configure the software in the following order.

- Step 1 Open browser, and enter the IP address of the WiseWay built-in card (KC502S)(default IP is 192.168.0.100).

**NOTE**





When the IP address of the SNMP built-in card(KC502S) is changed or multiple SNMP cards are used at the same time, the corresponding IP address can be obtained through WiseFind software(enter the address in PC to download the WiseFind software and then install it).

- Step 2 Enter the user name and password in the login page and click **Login** to enter the monitoring page.

NOTE

Default user name is admin, corresponding password is KHadmin0592.

User can scan the QR code or enter the URL through browser(PC mode)to get more product information.

User manual	Software			
WiseWay KC502	WiseClose	WiseFind	WiseInsight	WiseSMS
				
https://drive.263.net/link/YtH6Mi1Mtb0CpH/	https://drive.263.net/link/a0WjvayXwu0IQ4m/	https://drive.263.net/link/rvRBjZcMLiFrC1J/	https://drive.263.net/link/Rqk69m4ek9UGEKI/	https://drive.263.net/link/MzoJG31jCc3cC3H/

----End

2.4.2 Expansion Cards

Dry contact expansion card

The dry contact expansion card(as shown in Figure2-17) is mainly used for the detection signal collection. The dry contact expansion card includes three input dry contact communication signals and two output dry contact signals, the illustration is shown in Table2-10.

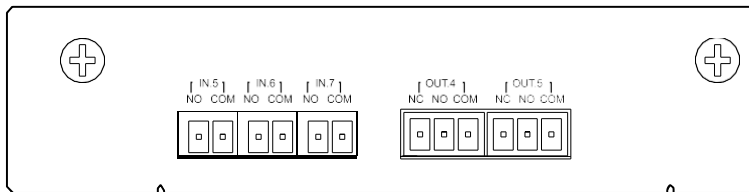

Figure2-17 Dry contact expansion card

NOTE

When the dry contact expansion card is selected, the dry contact expansion card will installed on the control unit of UPS.

Table2-10 Illustration of the dry contact

Port	Mark	Signal	Illustration
OUT.4	NC	OUT.4 normal close output port	When the signal is effective, COM and NO connect, and NC disconnects. This signal is settable.
	COM	Reinforced insulation ground	
	NO	OUT.4 normal open output port	
OUT.5	NC	OUT.5 normal close output port	When the signal is effective, COM and NO connect, and NC disconnects. This signal is settable.
	COM	Reinforced insulation ground	
	NO	OUT.5 normal open output port	
IN.5	NO	External switch normal open input port	When the NO and COM is short circuit, the signal is effective. This signal is settable.
	COM	Reinforced insulation ground	
IN.6	NO	External switch normal open input port	When the NO and COM is short circuit, the signal is effective. This signal is settable.
	COM	Reinforced insulation ground	
IN.7	NO	External switch normal open input port	When the NO and COM is short circuit, the signal is effective. This signal is settable.
	COM	Reinforced insulation ground	

The pin definition of the input dry contact and output dry contact are as shown in Table2-6 and Table2-7.

BMS expansion card

The BMS expansion card(as shown in Figure2-18) is mainly used for the Li-battery communication. The BMS expansion card includes one BMS communication port, two input dry contact and one output dry contact. The illustration is shown in Table2-11.

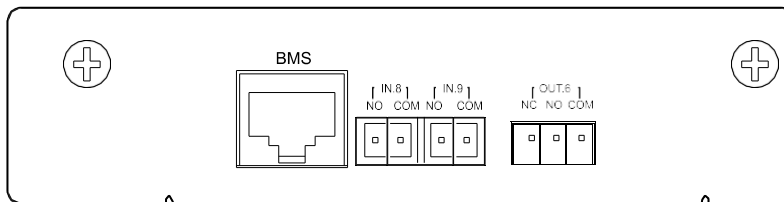

Figure2-18 BMS expansion card

NOTE

When the dry contact expansion card is selected, the dry contact expansion card will installed on the bypass unit of UPS.

Table2-11 Illustration of the BMS expansion card

Port	Mark	Signal	Illustration
BMS		BMS port	It is used to communicate with the Li-battery. BMS port adopts RJ45 plug. The pin definition of BMS port is shown in Figure2-19.
IN.8	NO	External switch normal open input port	When the NO and COM is short circuit, the signal is effective. This signal can be set to disable charging.
	COM	Reinforced insulation ground	
IN.9	NO	External switch normal open input port	When the NO and COM is short circuit, the signal is effective. This signal can be set to disable discharging.
	COM	Reinforced insulation ground	
OUT.6	NC	OUT.6 normal close output port	When the signal is effective, COM and NO connect, and NC disconnects. This port is reserved.
	COM	Reinforced insulation ground	
	NO	OUT.6 normal open output port	

NOTE

For LI-battery reliability consideration, if Li-battery is used, please contact with local agency or dealer.

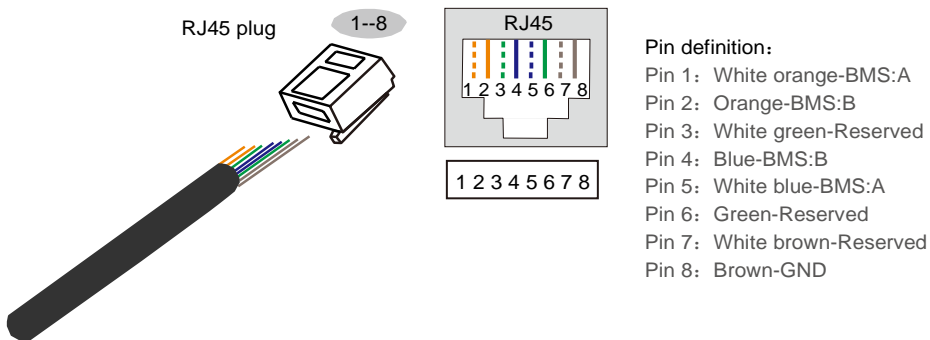

Figure2-19 Pin definition of BMS port

2.4.3 Parallel/BCS System Accessory

Parallel/BCS system accessory are for parallel/BCS ports connection between cabinets.

When multi UPSs in parallel, connect the parallel port of each UPS by parallel wire. N UPSs require N parallel wires to ensure there are at least two parallel wires for a UPS, which will improve parallel reliability.

The synchronous BSC output dual bus control is used in a dual bus system to synchronize the output frequency and phase of each system in a dual bus system to ensure that the two buses can switch to each other.

NOTE
The parallel wires are configured.

Parallel system connection

- Two UPSs

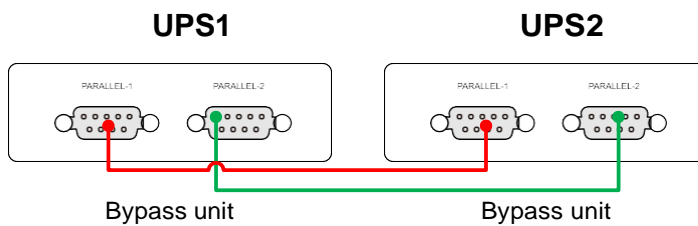

Figure2-20 Parallel system connection(Two UPSs)

- Multiple UPSs

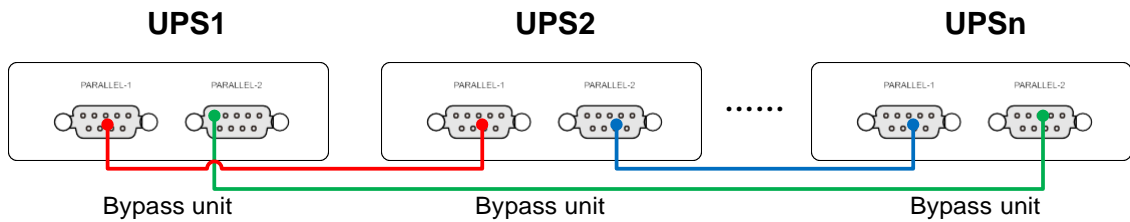

Figure2-21 Parallel system connection(Multiple UPSs)

NOTE
Wiring color in Figure2-20 and Figure2-21 just for display only, it cannot stands for the actual wire color, for specific color please see the actual wire.

2.4.4 Battery Temperature Compensation

The battery temperature compensation is used to monitor the battery temperature to realize the battery charging and discharging temperature compensation.

NOTE

When the battery temperature compensation function is selected, it will be configured that one temperature control wire, one temperature control extension cord and one 2Pin green terminal.

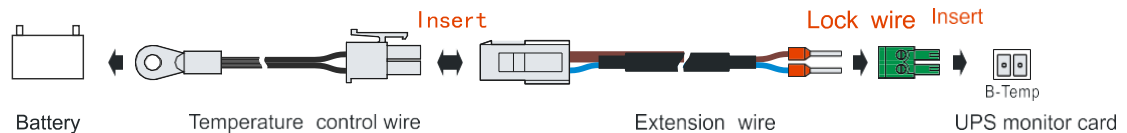

Figure2-22 Battery temperature compensation connection

NOTE

The temperature control wire should be fixed in the higher temperature area of the battery.

2.4.5 Surge Protection Device

If the UPS is installed in a lightning-prone area, it's should install multiple surge protection facilities in the wire inlet of mains to ensure that the device is safety running. The UPS can equipped with the surge protection device of grade-C. The SPD grade-C is optional for the series UPS.

NOTE

The lightning protection facilities are configured.

2.4.6 Battery Release Control Accessory

When the customer needs to install the battery release, it is necessary to add the corresponding battery release control accessory. The output voltage of the control accessory is 24VDC, and the voltage can be turned over through the dry contact control, which meets the supplier requirements of shunt release and under-voltage release.



NOTE



The output of the control accessory is 24VDC, so it can only meet the release that the power supply demand is 24VDC.



2.5 Alarm Function



When the UPS is abnormal, it will send sound & light alarm. The alarm or protection function of the UPS is as shown in Table2-12.

Table2-12 Abnormal status and alarm/protection function

Fault	Information	Protect requirement	Alarm requirement
Mains fault	Mains abnormal	Mains power supply is not allowed.	Buzzer slowly beeps, the "  " AC/DC indicator on the operation panel turns red, the mains icon on the touch screen turns red, and the yellow atmosphere lamp normal on.
	Mains over-voltage		
	Mains under-voltage		
	Mains unbalance		
	Mains over-frequency		
	Mains under-frequency		
	Mains power down		
	Mains phase loss		
	Mains phase sequence abnormal		
	Large mains harmonic		
	Mains drop		
	Mains input PFC overload		
	Mains neutral wire loss		
Large mains DC component			
Battery fault	Battery abnormal	Battery power supply is not allowed.	Buzzer fast beeps, the "  " BAT indicator on the operation panel turns red, the battery icon on the touch screen turns red, and the yellow atmosphere lamp normal on.
	Battery polarity reversed		
	Battery over-voltage		
	Charger over-current		
	Battery circuit abnormal		
	Bypass under-voltage protection		
	Bypass overload		
Bypass	Bypass abnormal	Bypass output is	Buzzer slowly beeps, the "

Fault	Information	Protect requirement	Alarm requirement
fault	Bypass over-voltage	not allowed.	 " Byp. indicator on the operation panel turns red, and the bypass icon on the touch screen turns red, and the yellow atmosphere lamp normal on.
	Bypass under-voltage		
	Bypass unbalance		
	Bypass over-frequency		
	Bypass under-frequency		
	Bypass power down		
	Bypass phase loss		
	Bypass phase sequence abnormal		
	Large bypass harmonic component		
	ECO power down detection		
ECO over-voltage			
ECO under- voltage			
ECO over-frequency			
ECO under-frequency			
Output fault	Inverter output abnormal	Inverter output is not allowed.	Buzzer long beeps, the "  " DC/AC indicator on the operation panel turns red, and the output icon on the touch screen turns red, and the red atmosphere lamp normal on.
	Output short circuit		
	Inverter over-voltage		
	Inverter under-voltage		
	Output circuit abnormal	None	Buzzer slowly beeps, the "  " DC/AC indicator on the operation panel turns red, and the output icon on

Fault	Information	Protect requirement	Alarm requirement
			the touch screen turns red, and the red atmosphere lamp normal on.
	Low output PF	Inverter output is not allowed.	Buzzer long beeps, the "  " DC/AC indicator on the operation panel turns red, and the output icon on the touch screen turns red, and the red atmosphere lamp normal on.
	Large output current DC component		
System fault	System fault	None	Buzzer long beeps and the red atmosphere lamp normal on.
	System EPO on	Bypass output and inverter output are not allowed.	
	System bypass abnormal	None	
	System inverter abnormal	None	
	EPO on	Bypass output and inverter output are not allowed.	
	Bypass overload protection	Bypass output and inverter output are not allowed.	Buzzer long beeps, the "  " OVERLOAD indicator on the operation panel turns red, and the output icon on the touch screen turns red, and the red atmosphere lamp normal on.
	Bypass SCR abnormal	Bypass output is not allowed	Buzzer long beeps, the "  " Byp. indicator on the operation panel turns red, the bypass icon on the touch



Fault	Information	Protect requirement	Alarm requirement
			screen turns red, and the red atmosphere lamp normal on.
	Parallel wire abnormal	Inverter output is not allowed	Buzzer long beeps, and the red atmosphere lamp normal on.
	Parallel system sovereignty fault	None	Buzzer long beeps, and the red atmosphere lamp normal on.
	Inverter overload protection	Inverter output is not allowed	Buzzer long beeps, the "  " OVERLOAD indicator on the operation panel turns red, the output icon on the touch screen turns red, and the red atmosphere lamp normal on.
	Maintenance bypass on	Inverter output is not allowed	Buzzer long beeps, and the red atmosphere lamp normal on.
	Battery charge disabled on	None	Buzzer fast beeps, the "  " BAT indicator on the operation panel turns red,
	Battery discharge disabled on	None	the battery icon on the touch screen turns red, and the red atmosphere lamp normal on.
Cabinet fault	Cabinet fault	None	Buzzer long beeps, and the red atmosphere lamp normal on.
	Bypass over-temperature	Check whether bypass output or not by the bypass over-temperature	Buzzer long beeps, the "  " Byp. indicator on the operation panel turns red, the bypass icon on the touch

Fault	Information	Protect requirement	Alarm requirement
		enable.	screen turns red, and the red atmosphere lamp normal on.
	Inverter output over-current	None	Buzzer long beeps, and the red atmosphere lamp normal on.
	Rectifier abnormal self-locking	None	
	Inverter abnormal self-locking	None	
	Battery overload protection	None	
	Battery discharge protection end	None	
	UPS abnormal	None	
Cabinet pre-alarm	Cabinet pre-alarm	None	Buzzer fast beeps, and the yellow atmosphere lamp normal on.
	Cabinet over-temperature alarm	None	
	High battery temperature alarm	None	
	Low battery temperature alarm	None	
	Battery under-voltage alarm	None	
	Battery backup time insufficient	None	
	Output overload alarm	None	Buzzer fast beeps, the "  " OVERLOAD indicator on the operation panel turns red, the output icon on the touch screen turns red, and the yellow atmosphere lamp normal on.
	Output frequency out of scope	None	Buzzer fast beeps, and the yellow atmosphere lamp normal on.
	Bypass auxiliary power abnormal	None	
	Bypass over-temperature alarm	None	
	Some power units PFC	None	

Fault	Information	Protect requirement	Alarm requirement
	abnormal		
	Auto-start once power recover function disable	None	
Cabinet alarm	Cabinet abnormal	None	Buzzer slowly beeps, and the yellow atmosphere lamp normal on.
	Battery circuit disconnect	None	
	Auxiliary power abnormal	None	
	Setting parameters mismatched	None	Buzzer slowly beeps, and the yellow atmosphere lamp normal on.
	Battery parameters mismatched	None	
	Unit number inconformity	None	
	Cabinet number inconformity	None	
	Flash abnormal.	None	
	Bypass output	None	
	Repeat slot address	None	
	System card n _ output status out of sync	None	
	Fan dedusting	None	
Startup fault alarm	Startup fault alarm	Static startup is not allowed to work.	Buzzer slowly beeps, and the yellow atmosphere lamp normal on.
	Reserved		
	Cannot inverter output for heavy load		
	Waiting common inverter for unknown load		
	PFC software version inconformity		
	INV software version		

Fault	Information	Protect requirement	Alarm requirement
	inconformity		
	CCM software version inconformity		
	Unit hardware version inconformity		
	Key parameters mismatched		
	Parallel address conflict		
	Unit serial version inconformity		
Component failure alarm	Component failure	None	Buzzer slowly beeps, and the yellow atmosphere lamp normal on.
	Bypass 1 NTC failure		
	Bypass 2 NTC failure		
	Cabinet NTC failure		
	System card NTC failure		
	Bypass fan abnormal		
	Cabinet fan abnormal		
	Parallel wire 1 alarm		
	Parallel wire 2 alarm		
	Monitor card is not installed		
	Bypass unit offline	Bypass output is not allowed.	Buzzer slowly beeps, the "  " Byp. indicator on the operation panel turns red, and the bypass icon on the touch screen turns red.
	Expansion card offline	None	Buzzer slowly beeps.
	Bypass NTC failure		

Fault	Information	Protect requirement	Alarm requirement
Comm. abnormal alarm	Communication abnormal	None	Buzzer fast beeps, and the yellow atmosphere lamp normal on.
	Sync CAN inside cabinet abnormal		
	Equalized-current CAN inside cabinet abnormal		
	BMS communication fault		
	Display CAN inside cabinet abnormal		
	Parallel sync CAN abnormal		
	Parallel equalized-current CAN abnormal		
Smart mode alarm	Smart mode alarm	None	Buzzer slowly beeps, and the yellow atmosphere lamp normal on.
	Start generator mode		
	Generator charge disabled		
	Only one BCS system has been detected.		
	The load exceeds the set safety load		
	UPS no redundancy		
	UPS redundancy insufficient		
	Cabinet no redundancy		
	Cabinet redundancy insufficient		
	System card no redundancy		

Fault	Information	Protect requirement	Alarm requirement
	Self-load switch abnormal		
	Self-load over-time alarm		
	Inverter bypass out of sync		
Input dry contact status	Input dry contact alarm	None	Buzzer slowly beeps, and the yellow atmosphere lamp normal on.
	Battery abnormal		Buzzer fast beeps, the "  " BAT indicator on the operation panel turns red, the battery icon on the touch screen turns red, and the yellow atmosphere lamp normal on.
	Battery grounding abnormal		
	Battery switch opened		Buzzer slowly beeps, the "  " Byp. indicator on the operation panel turns red, the bypass icon on the touch screen turns red, and the yellow atmosphere lamp normal on.
	Bypass switch opened		Buzzer slowly beeps, and the yellow atmosphere lamp normal on.
	Output switch opened		Buzzer fast beeps, the "  " BAT indicator on the operation panel turns red, the battery icon on the touch screen turns red, and the yellow atmosphere lamp normal on.
	Battery discharge disabled on		

Fault	Information	Protect requirement	Alarm requirement
	Battery charge disabled on		Buzzer fast beeps, the "  " BAT indicator on the operation panel turns red, the battery icon on the touch screen turns red, and the yellow atmosphere lamp normal on.
	Generator mode		Buzzer slowly beeps, and the yellow atmosphere lamp normal on.
	SPD abnormal		Buzzer slowly beeps, and the yellow atmosphere lamp normal on.
Offline alarm status	Power unit 1 offline	None	Buzzer slowly beeps.
	Power unit 2 offline		



CAUTION

In the battery under-voltage protection, if the mains is normal, the UPS will restart and charge the battery group.

3 Installation

This chapter mainly introduces the installation of the UPS, including unpacking and checking, installation procedure, installation preparation, mechanical installation and system checking and test, etc.



CAUTION

The UPS should be installed by authorized person who is special trained and achieve the qualification of high-voltage and AC power.

The UPS is just suitable for installing on the concrete or nonflammable surface.

3.1 Installation Procedure

The installation procedure of the UPS is as shown in Figure3-1.

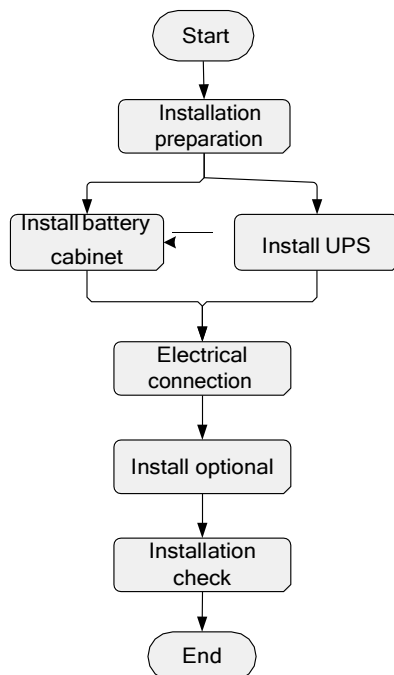
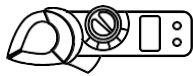

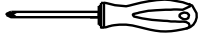
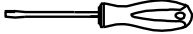

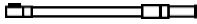



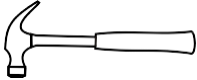
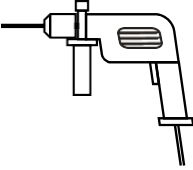
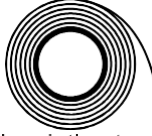

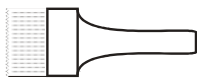
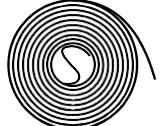
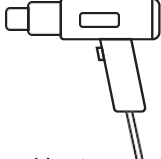

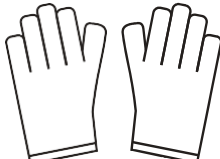
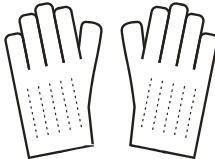
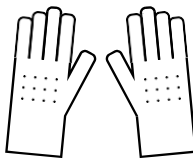



Figure3-1 Installation procedure

3.2 Installation Preparation

3.2.1 Installation Tools

Tools			
 Clamp meter	 Multi-meter	 Label paper	 Phillips screwdriver
 Flat-head screwdriver	 Socket wrench	 Adjustable wrench	 Torque wrench
 COAX crimping tool	 Diagonal pliers	 Wire stripper	 Claw hammer
 Hammer drill	 Insulation tape	 Cotton cloth	 Brush
 Heat shrink tubing	 Heat gun	 Electrician's knife	 Protective gloves
 ESD gloves	 Insulated gloves	 Hydraulic pliers	 Cable tie

**CAUTION**

The installation tools should be with isolated operation, which is to avoid electric shock.

3.2.2 Installation Environment

- Do not install the UPS in the place where exceeds the provision of technology index (temperature: $-5^{\circ}\text{C} \sim 40^{\circ}\text{C}$, relative humidity: 0%~95%).
- It is strictly prohibit installing the UPS in the environment with metal conductive dust.
- Do not install the UPS in the open air, and the installation environment should meet the provision requirements.
- Basic requirements for power supply:
 - Grounding preparation. Ensure that the grounding terminal is OK and the voltage between neutral wire and grounding wire should not exceed 5V.
 - Before installation, please ensure that the AC input voltage and mains input wire capacity meet the UPS requirements. And considering if there has current-carrying capacity descending caused by wire aging.
 - The mains input voltage range of the UPS is 80VAC-280VAC. The mains capacity should be greater than the max. input power of the UPS.
 - The selected switch should not with leakage current protection.
- The installation environment of the UPS should be with good ventilation, and far away from water source, heat source and inflammable and explosive objects. Avoid installing the UPS in the place where has direct sunshine, dust, volatile gas, corrosive objects or high salt.
- The UPS is just suitable for using below 2000m. If the altitude exceed 2000m, it needs to decrease the rated power according to GB/T7260.3-2003 and IEC 62477-1 touse.

**CAUTION**

The optimal operating temperature for batteries is 20~30°C. Operating at temperatures lower than 20°C will shorten the battery backup time, and operating at temperatures higher than 30°C will shorten the battery lifespan.

For safety, make sure that the external DC distribution circuit is configured with a tripolar disconnecting switch.

3.2.3 Installation Space

Maintain a clearance of at least 800mm from the front panel, side pane or rear panel of the UPS to the wall or adjacent device, and maintain a clearance of at least 800mm from the top of the UPS to ceiling, which is to ensure good ventilation, as shown in Figure3-2.

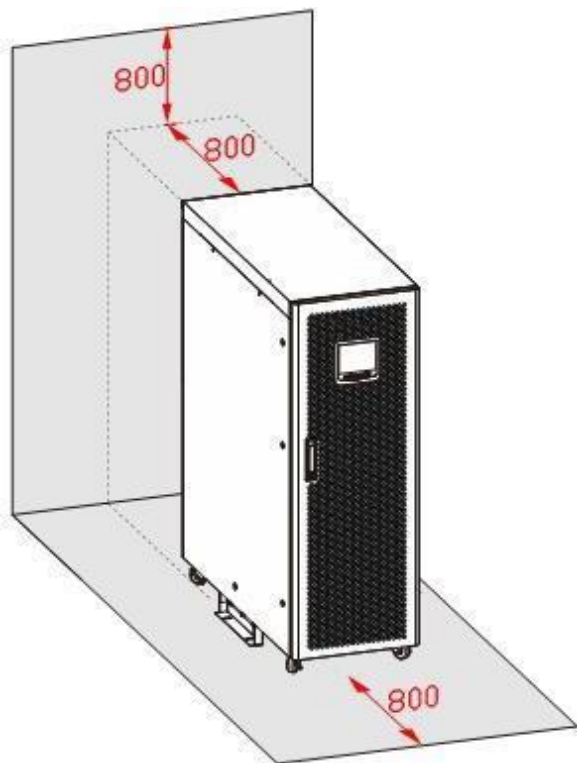

Figure3-2 Installation space (unit: mm)

**NOTE**

The installation space requirement of series UPS is the same. In above figure, we take 60K UPS as an example to illustrate.

- Avoid any object block the ventilation hole on the front panel and rear panel, which is to keep good ventilation for the UPS, or, it may rise the inner temperature, even influence the UPS service time.

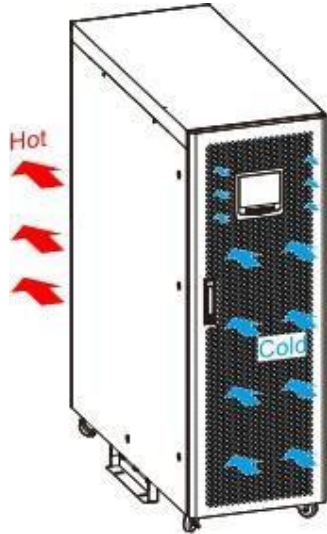

Figure3-3 Heat-dissipating



NOTE

The installation space requirement of series UPS is the same. In above figure, we take 60K UPS as an example to illustrate.

3.2.4 Selection for Input and Output Wires

For the wire sectional area selection of AC input and output wires, please refer to Table3-1 for corresponding recommended values.

Table3-1 Recommended wire and terminal specification

Item		Model	120K
Mains input	Mains input current (A)		196
	Recommended wire sectional area (mm ²)	U/V/W/N	70×1
	Terminal		DT-70

Item		Model	120K
Bypass input	Bypass input current (A)		182
	Recommended wire sectional area (mm ²)	U/V/W/N	70×1
	Terminal		DT-70
Output	Output current(A)		182
	Recommended wire sectional area (mm ²)	U/V/W/N(when the load is non-linear load, the N wire should increase the wire sectional area)	70×1
	Terminal		DT-70
Battery input	Battery nominal discharge current(A)		289
	Battery max. discharge current (A)		372
	Recommended wire sectional area (mm ²)	+/N/-	70×2
	Terminal		DT-70
Grounding wire	Recommended wire sectional area (mm ²)	PE	35×1

Item	Model 120K
Terminal	DT-35

**NOTE**

The wires prepared by our company have passed the GB or UL certification. The wires quality is excellent, and all meet the production compliance. The cross-sectional areas above are recommended for 5 meters long wires. If the wire length exceeds 5 meters, please consult our company for the cross-sectional areas of the wire.

3.3 Transportation and Unpacking

3.3.1 Transportation

**CAUTION**

The UPS should be transported by trained professional.

During transporting, please take care and avoid impact or falling off.

If the UPS needs to be stored for a long time after unpacking, it is suggested to package the UPS with original plastic bag.

The UPS can be transported by motor-driven forklift (as shown in Figure3-4) or manual forklift (as shown in Figure3-5). While lifting, please keep the UPS center of gravity at that of the forklift and move slowly and stably.



Figure3-4 Motor-driven forklift

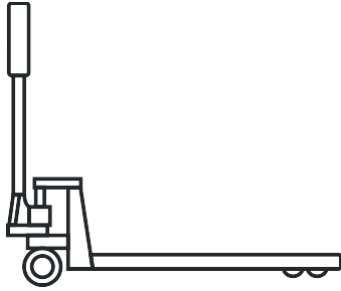

Figure3-5 Manual forklift

**CAUTION**

When lifting, pay attention to the balance and stable of the UPS.

During moving, keep the UPS vertical and do not put down or uplift suddenly.

3.3.2 Unpacking

Step 1 Check if the package appearance is in good condition and if there is any damage caused by transportation. If damaged, please inform the carrier immediately.

Step 2 Transport the UPS to assigned site.

**CAUTION**

To avoid tilting during transportation, keep the forklift arm exceeding the wooden bracket.

Step 3 Unpack the external package, remove the foam pad and plastic bag, and take out the accessories.

Step 4 Check the UPS.

- Inspect the appearance of the UPS and check if there has any damage caused by transportation. If any damage, please inform the carrier immediately.
- Compare with the packing list and check if the accessories mode is complete and proper. If the accessories lack or model wrong, please take note and contact the our company or local agency of our company.

Step 5 Loosen the fasten bolts.

- 120K

Loosen the six M8 hexagon bolts of supporting plate and UPS by wrench, then loosen the four M10 hexagon bolts of wooden bracket and supporting plate(as shown in Figure3-6). Remove the supporting plate after make the wheels of the UPS in contact with the wooden bracket(as shown in Figure3-7).

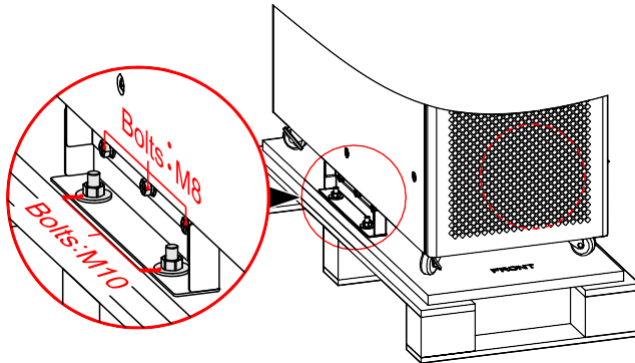

Figure3-6 Dismantle the supporting plate of 120K

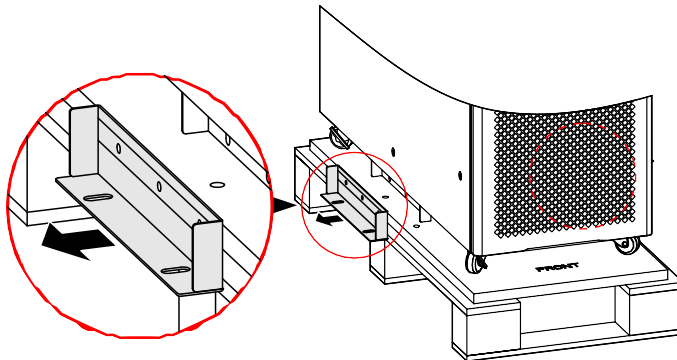

Figure3-7 Dismantle the supporting plate of 120K

---End

3.4 Mechanical Installation

3.4.1 120K

Step 1 Determine and plan the installation position according to the UPS size (as shown in Figure3-9) and installation clearance requirement (see **3.2.3 Installation Space**).

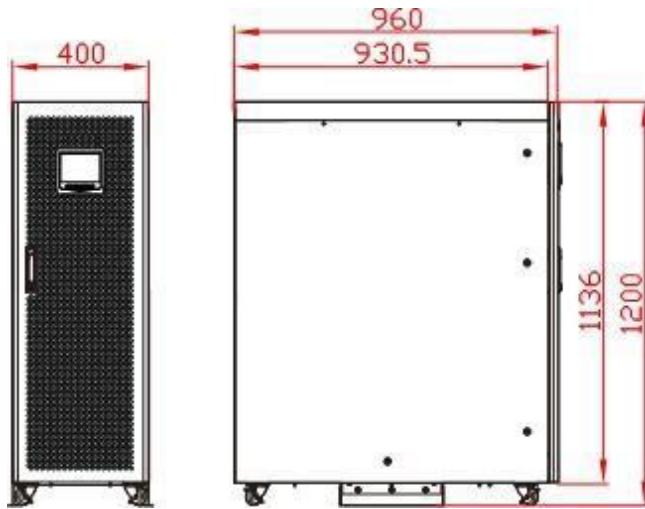

Figure3-9 Size

Step 2 Drill four holes of $\Phi 14.5$ by hammer drill according to the installation size of pedestal (as shown in Figure3-10).

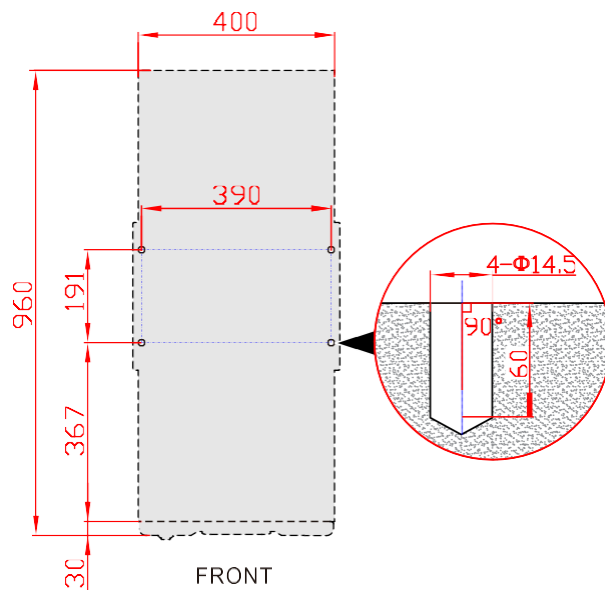

Figure3-10 Bottom installation size (bottom view of pedestal)(unit: mm)

NOTE

- The recommended bolts is M10, corresponding drilling depth is 60mm, which can be adjusted according to the actual installation situation.
- If channel steel is used for installation, drill four installation holes $\phi 14\text{mm}$ on the channel steel directly according to the drilling size shown in Figure3-11, and then install it directly according to **Step 4**.

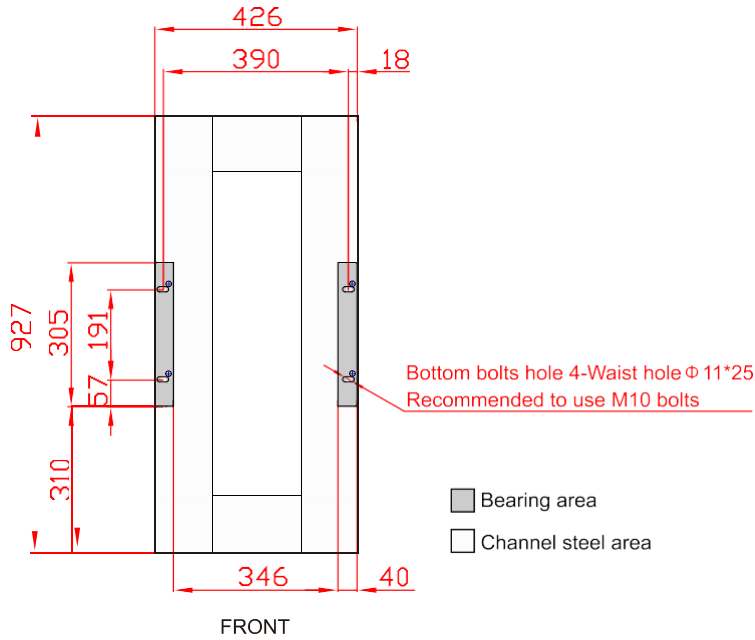

Figure3-11 Recommended installation size for channel steel (unit: mm)

Step 3 Install the expansion bolt, as shown in Figure3-12.

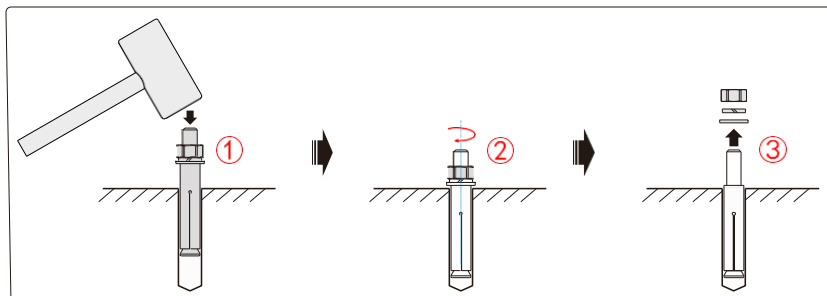

Figure3-12 Install expansion bolts



CAUTION

The expansion tube shouldn't be higher than the ground, which is to avoid affecting the installation.

 **NOTE**

The exposed height of expansion bolt must be within 30mm to 50mm.

Step 4 Fasten the supporting plate. Put the supporting plate on the ground where has been drill the expansion bolts. Install the flat gasket($\Phi 10$), spring gasket($\Phi 10$) and bolts($\Phi 10$), then pre-screw the bolts, as shown in Figure3-13.

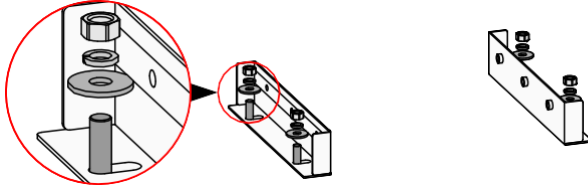

Figure3-13 Fasten the supporting plate

Step 5 Move the UPS from wooden bracket to the installation site, lock UPS with supporting plate by six M8 hexagon bolts, as shown in Figure3-14, then screw the bolts of supporting plate.

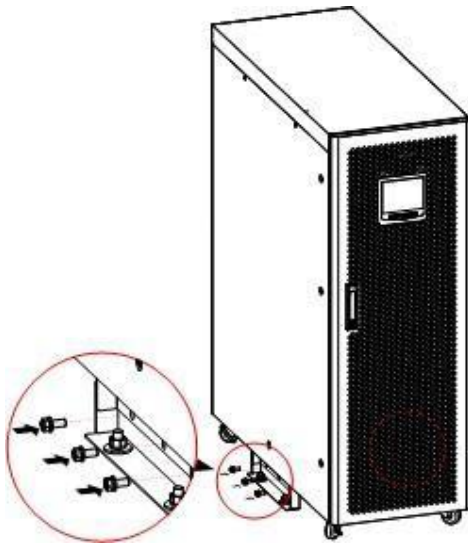

Figure3-14 Fasten the UPS

----End

3.4.3 Optional Accessory Installation

If the SNMP card or expansion card is an independent product, install it in the installation position.

SNMP card

Step 1 Dismantle the SNMP card cover plate on the bypass unit, as shown in Figure3-21.

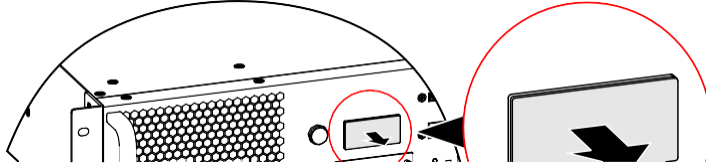

Figure3-21 Dismantle the SNMP card cover plate

Step 2 Take the SNMP card and install it on the bypass unit by 2 bolts, as shown in Figure3-22.

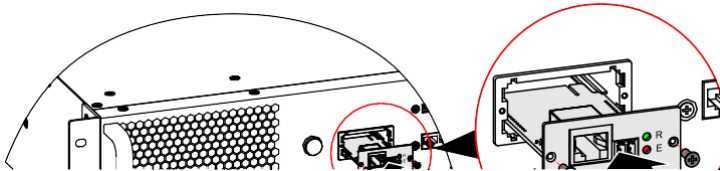

Figure3-22 Install SNMP card

---End

BMS expansion card/Dry contact expansion card



NOTE

The installation way for the dry contact expansion card and the BMS expansion card is the same. Here we take the BMS expansion card as example.

Step 1 Loosen the screws of the expansion card plate on the bypass unit, and then take down the expansion card cover plate, as shown in Figure3-23.

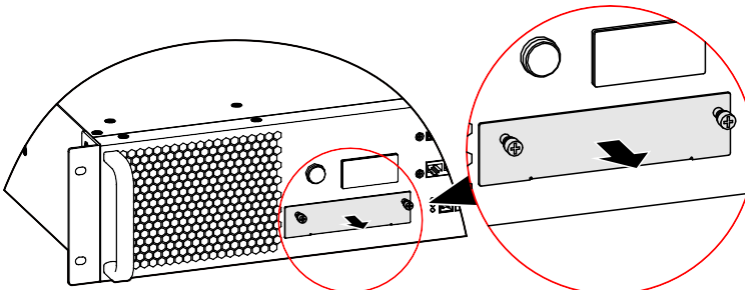

Figure3-23 Dismantle the expansion card cover plate

Step 2 Take the expansion card and install it on the bypass unit, as shown in Figure3-24.

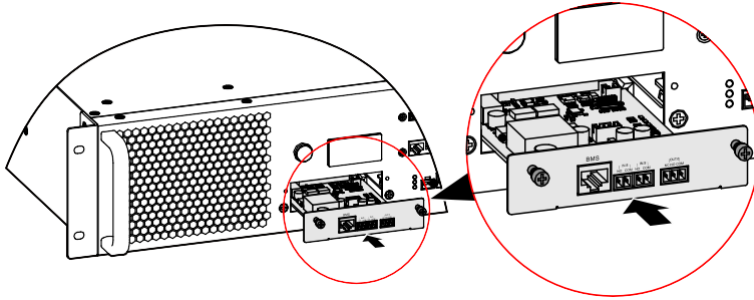

Figure3-24 Install the expansion card

---End

3.4.4 Battery Release Control Accessory Installation



DANGER

Ensure that the UPS is completely shutdown before install the battery release control accessory.

The UPS needs to be equipped with function of battery release after ex work, the battery release accessory needs to be installed on site.



NOTE

Please contact our customer service for specific routing and installation.

Step 1 Take out the PCB of battery release, then install it in UPS rear with five bolts M4, installation position as shown in Figure3-25, Figure3-26.

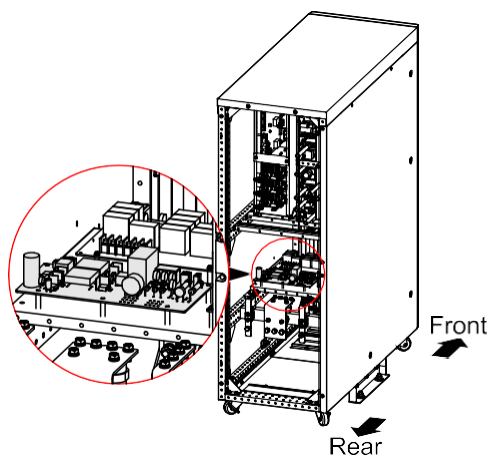

Figure3-25 Installation position of PCB for 120K

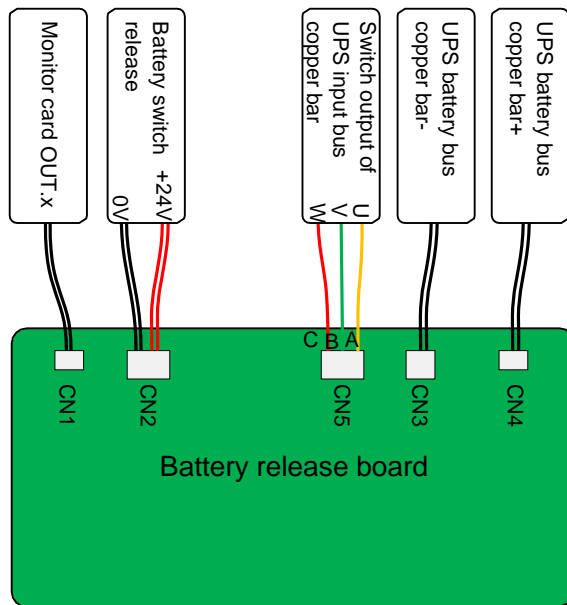

Figure3-27 Illustration for terminal connection of battery release

----End

3.4.5 Install Battery Cabinet

Important safety rule



DANGER

Do not open or disassemble the battery, for the inner electrolyte is harmful for eyes. If contacting the electrolyte with careless, please wash the contact part with plenty water and go to hospital immediately.

To avoid electric shock and short circuit while replacing battery, pay attention to following precautions.

- Do not wear watch, ring or other metal decorations.
- Use the tool with insulation handle.
- Do not put any tool or metal object on the battery.
- Keep the battery far away from fire, no smoking.

Battery cabinet installation procedure



CAUTION

The assemble for the external battery should be performed by professional technician.

Besides the UPS, it is necessary to equip battery and battery cabinet. The installation procedure for battery cabinet is as follows.

Step 1 Connect the wires of external batteries properly.



CAUTION

Before connecting, please ensure that the switch of battery cabinet is not connected to the terminal bar of the UPS.

Step 2 After disconnecting the battery switch, connect the power wire of battery switch to the anode, cathode and neutral wire N of the UPS correspondingly. Ensure that the polarity and voltage meet the specification requirement, and then close the switch between the UPS and batteries.

----End

After assembly and test, the UPS can put into use.

3.5 Wiring

Recommend that add the contactor of 220V AC coil in AC side for reverse feedback protect device.

3.5.1 120K

Step 1 Open the front door of the UPS, remove the front and rear wiring cover plate, as shown in Figure3-28.

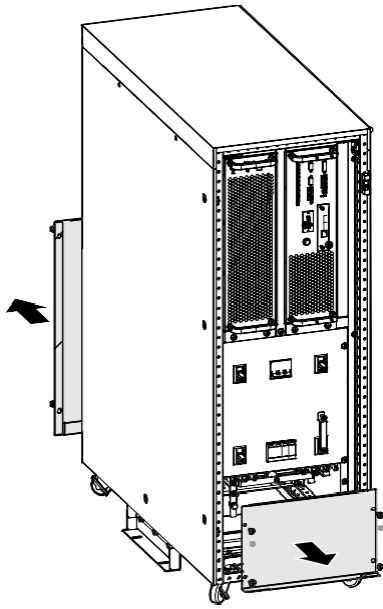

Figure3-28 Remove the cover plate of wiring

Step 2 Lead the input cables, output cables, battery cables and PE go through the bottom wiring hole (the diagrams of down wiring hole are as shown in Figure3-29), and connect the cables with terminal bars according to Figure3-30 respectively, then fasten the bolts.



CAUTION

When wiring, make sure that wires are connected with terminals tightly. Do not make any poor connection or connect wires reversely

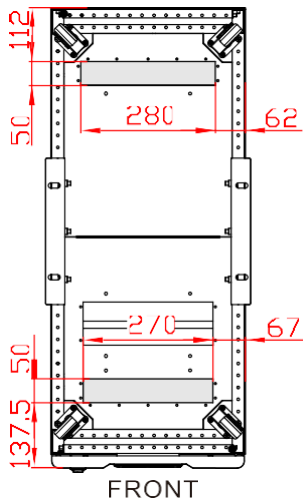

Figure3-29 Down wiring holes diagram of 120K

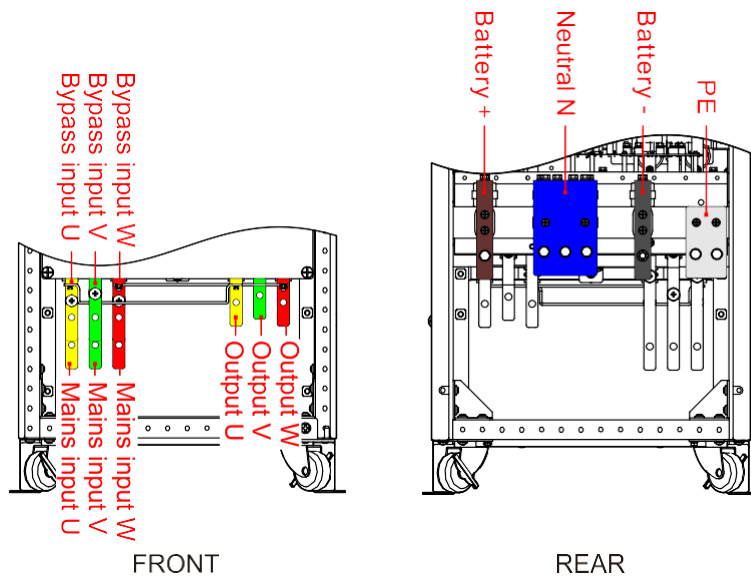

Figure3-30 Wiring terminal diagram of 120K

**NOTE**

When mains and bypass in one source, the terminal bars of mains and bypass as the mains input, bypass wiring terminal preferred.

The position of input N and battery N in the same terminal bar at the rear of UPS 60K, 80K, 100K, 120K.

**CAUTION**

When wiring, ensure that the connection between input/output wire and input/output terminal is reliably, avoid bad connection or wrongly connection.

**NOTE**

120K equip the mains and bypass in one source. When customers need wiring that mains and bypass in different source, they need to remove the three copper bars (as shown in Figure3-31) that are short circuited the mains and bypass, and then connect the mains and the bypass respectively.

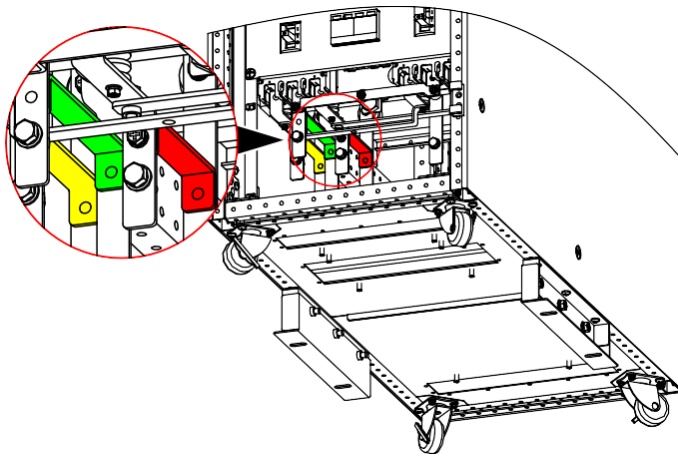

Figure3-31 Short circuit bars position of mains and bypass

It is suggested to select DC switch for battery DC input, the detail wiring is as shown in Figure3-32.

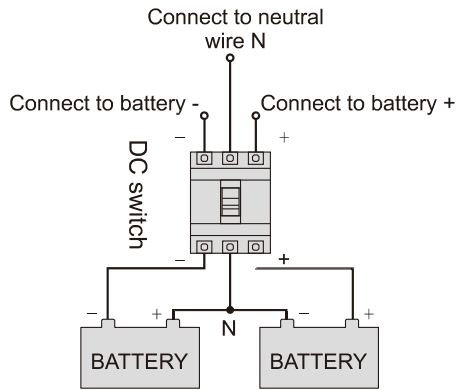

Figure3-32 Battery wiring diagram

Step 3 Lead the communication wires go through the wiring hole and connect them to corresponding ports and ensure reliable connection.

Step 4 Reinstall the bottom wire seal plate, the wiring is finished.

---End

3.6 System Check and Test

3.6.1 Check Electrical Connection

After finishing the electrical connection, check the following items.

Table3-2 Check list

NO.	Check item	Result
1	Check if the color of AC cables is in accordance with the specification.	Yes <input type="checkbox"/> No <input type="checkbox"/>
2	Check if the wiring of cabinet is firmly.	Yes <input type="checkbox"/> No <input type="checkbox"/>
3	Check if the safety identification of AC power distribution unit is complete.	Yes <input type="checkbox"/> No <input type="checkbox"/>
4	Check if the wire connection point is firmly.	Yes <input type="checkbox"/> No <input type="checkbox"/>
5	Check if the battery is connected in right polarity and sequence.	Yes <input type="checkbox"/> No <input type="checkbox"/>
6	Check if the cable identification is correct.	Yes <input type="checkbox"/> No <input type="checkbox"/>
7	Check if the wiring is neat, and if the cable connection is in accordance with the specification.	Yes <input type="checkbox"/> No <input type="checkbox"/>
8	Check if the equipment installation and wiring is advantageous to the transformation, expansion and maintenance of the system in the future.	Yes <input type="checkbox"/> No <input type="checkbox"/>

3.6.2 UPS Test

Turn off the mains input switch to simulate the situation of mains fault. When mains fault, the UPS turns to battery inverter, the touch screen will show the alarm and the buzzer will beep every 1s.

3.6.3 Connect Load

After UPS starting and working stably, turn on the load. Start big-power devices before small-power ones. Some devices has large starting current which may cause overload protection (or bypass operation), it is better to start these equipment before others.

4 Touch Screen Operation and Setting

This chapter mainly introduces the work parameters and work status and system setting of the UPS.

4.1 LCD Interface Flowchart

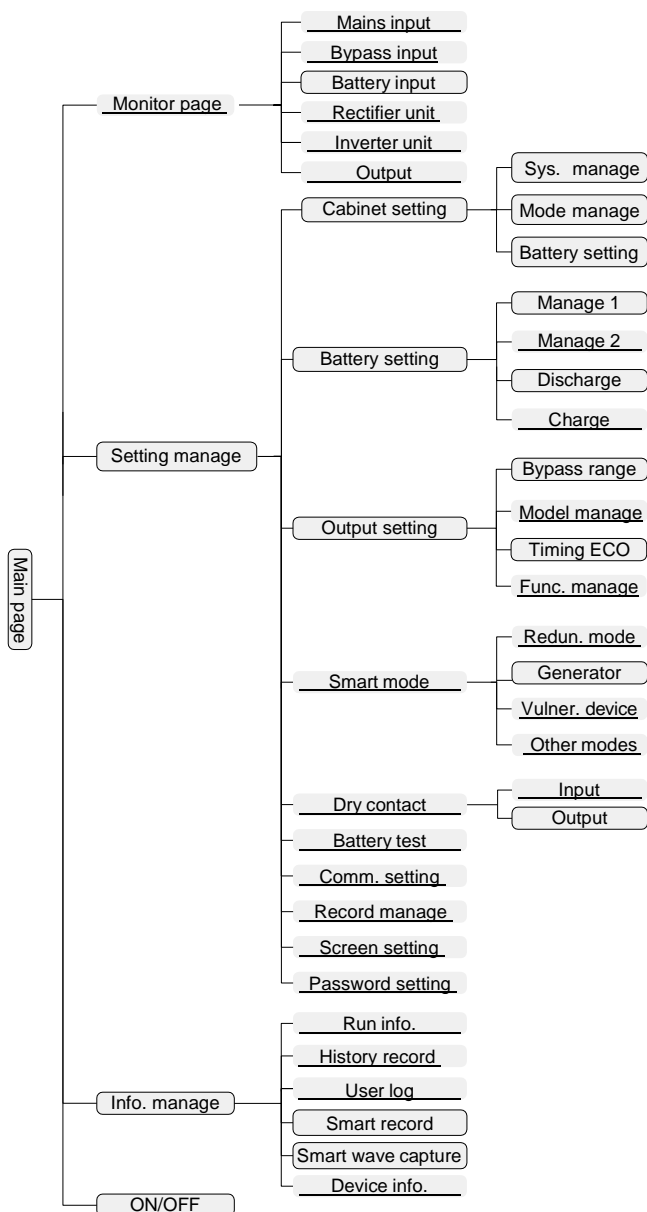

Figure4-1 Menu structure

 **NOTE**

The value in the figures of this chapter is just for illustration, for real interface please see the actual product.

4.2 Main Page

After powering on, it will enter the main page, as shown in Figure4-2.

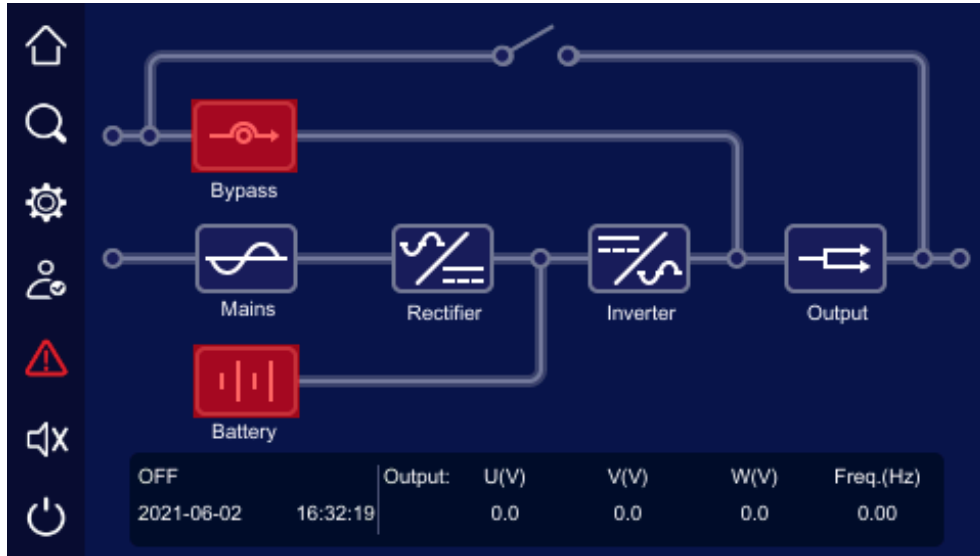







Figure4-2 Main page



After entering the main page, user can monitor the system conveniently. The icon meaning on the main page is as follows.



: System bypass input. When bypass input abnormal, the icon flickers and shows as .

: System mains input. When mains input abnormal, the icon flickers and shows as .







: Rectifier information. Click the icon, you can select and check the rectifier information of each unit.

: Inverter information. Click the icon, you can select and check the inverter information of each unit.

: Battery status. When battery abnormal, the icon flickers and shows as .

: System output status. When output abnormal, the icon flickers and shows as .

: Back to main page.

- : Information record.
- : System parameter setting.
- : Login.
- : Buzzer control.
- : Alarm.
- : ON/OFF.

The working status and energy flow on the main page shows the system running status and unit running condition directly.

4.3 System Work Status Display

The system working status includes: abnormal protection, shutdown, bypass output, inverter output, grid-tied self-load running, ECO bypass output, frequency converter output, maintenance bypass output, grid-tied self-aging shutdown. Each page is as shown from Figure4-3 to Figure4-11.

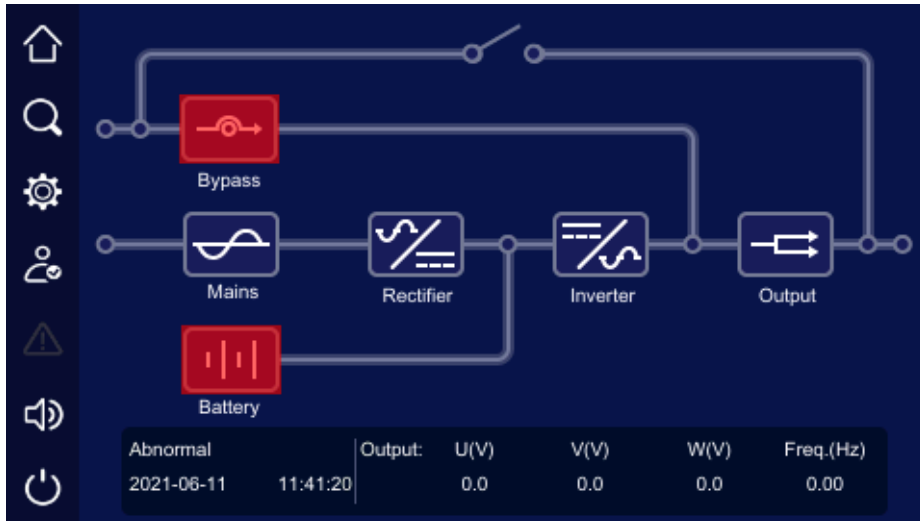

Figure4-3 Abnormal protection, with no output

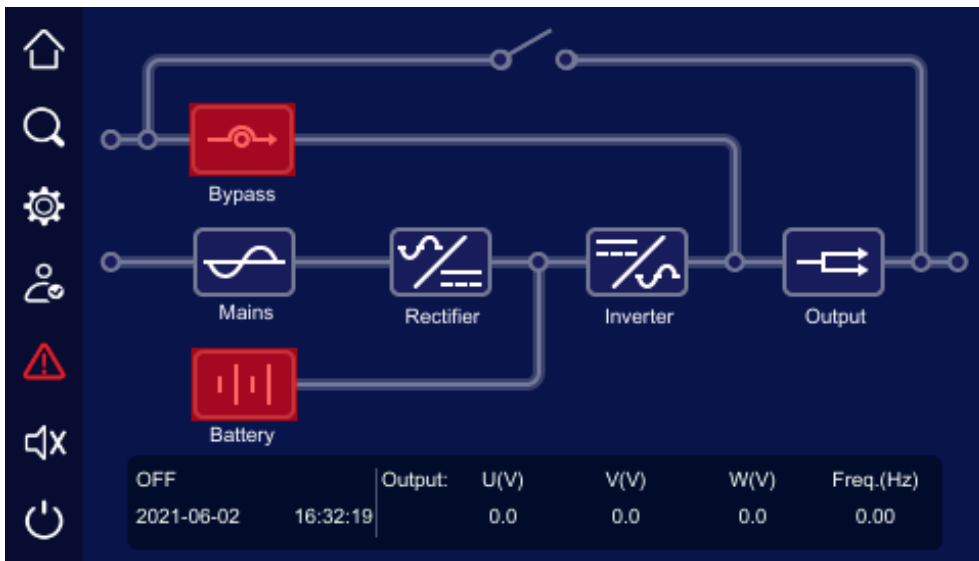

Figure4-4 Shutdown

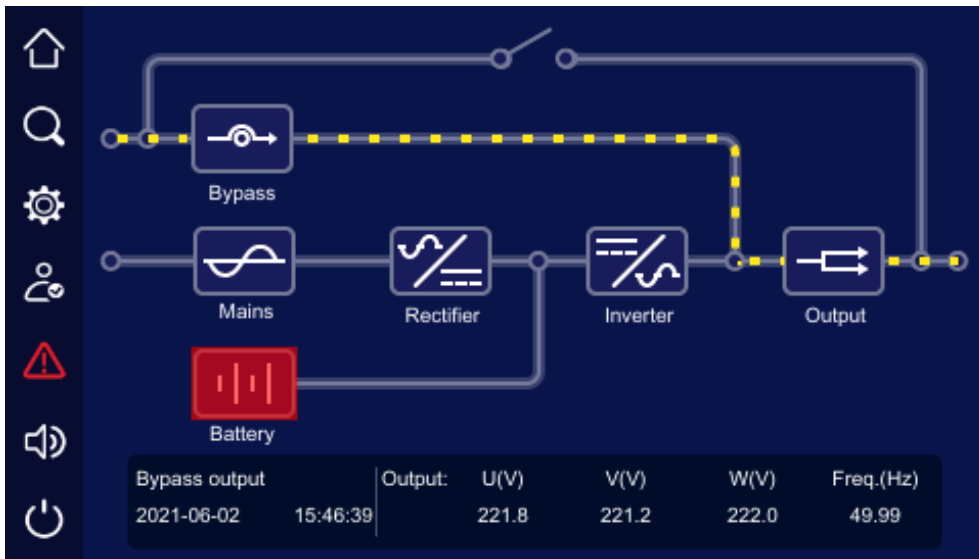

Figure4-5 Bypass output

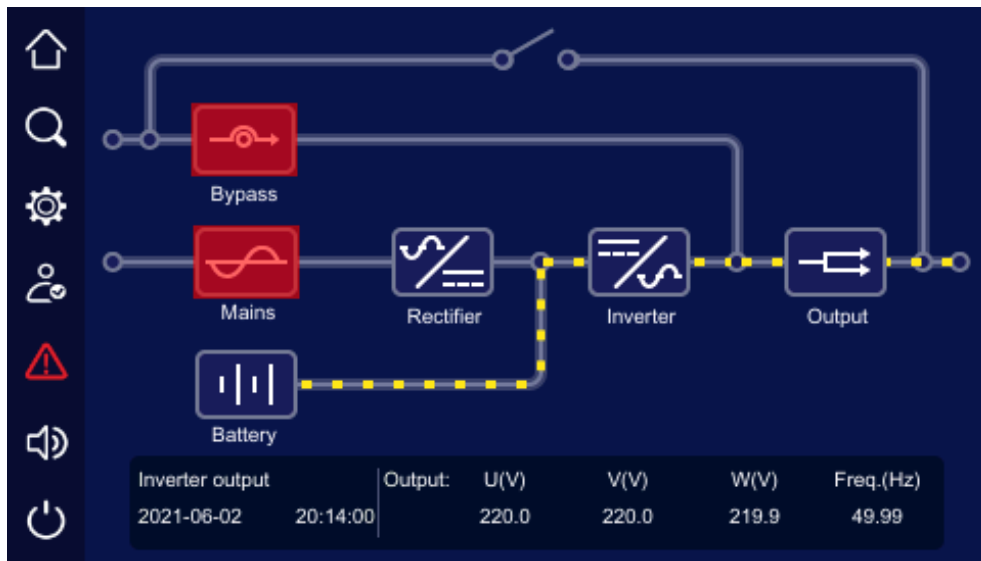

Figure4-6 Battery inverter output

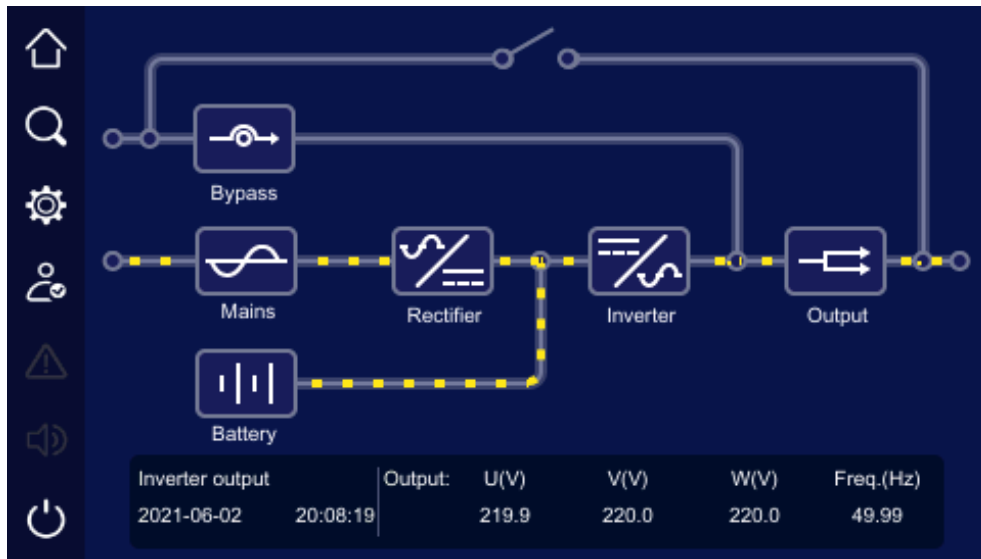

Figure4-7 Mains inverter output

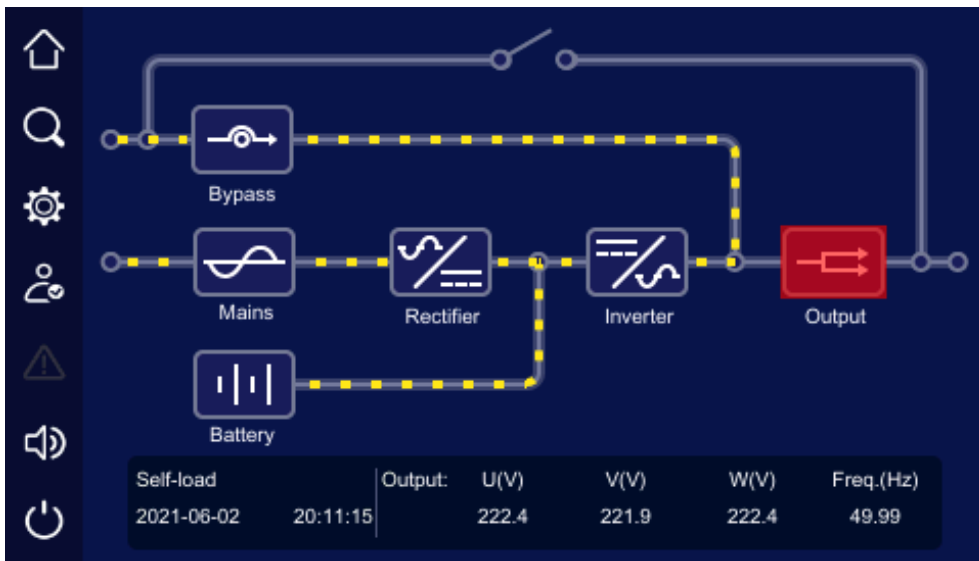

Figure4-8 Grid-tied self-load running

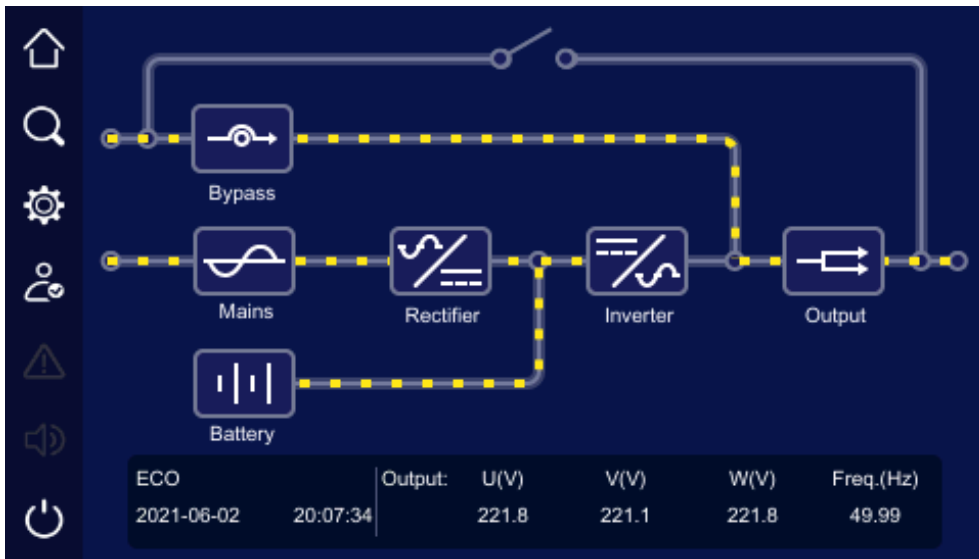

Figure4-9 ECO bypass output

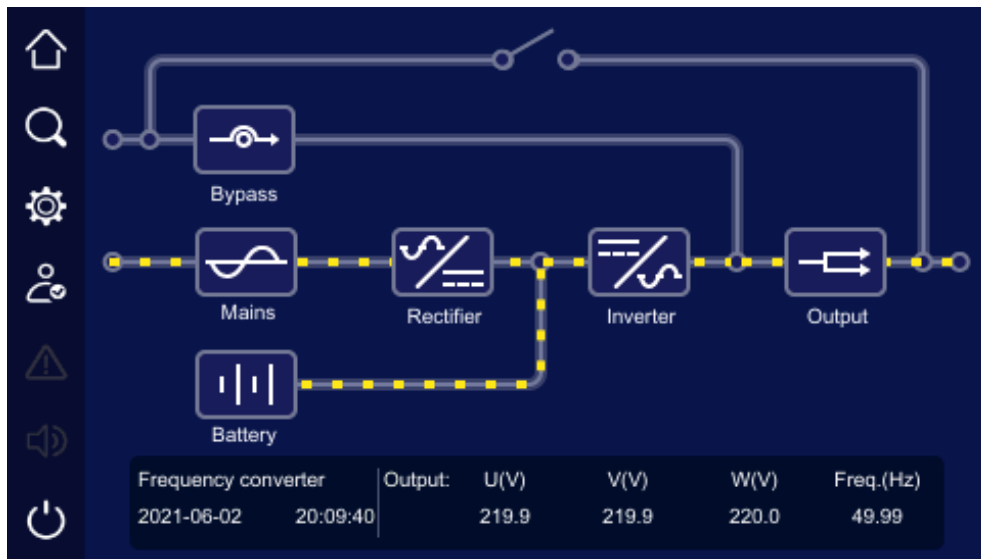

Figure4-10 Frequency converter output

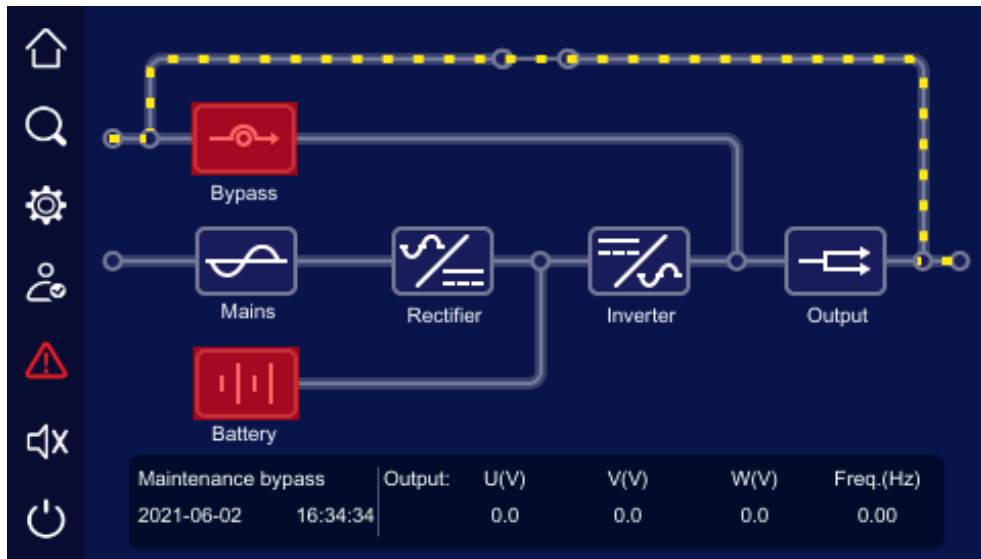

Figure4-11 Maintenance bypass output

When unit or system abnormal, the main page will show "Abnormal alarm" indicator, click the "Abnormal alarm" indicator, it will show the current fault information, as shown in Figure4-12.

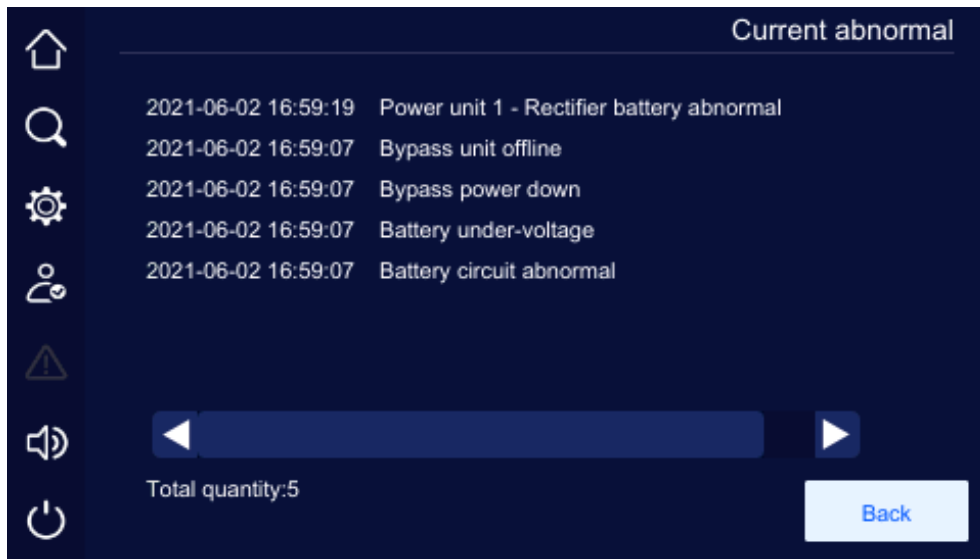



Figure4-12 Current abnormal information

4.4 Buzzer Control Function

When unit or system abnormal, the system will send sound alarm. User can click the  icon at left to close or open the buzzer. After closed, if there is new fault, the buzzer will be opened automatically.

4.5 Monitor Page

4.5.1 Mains Input Information

In main page, click  icon, it will enter the mains information page, as shown in Figure4-13. In the page, it shows the mains phase voltage, mains current, mains frequency.

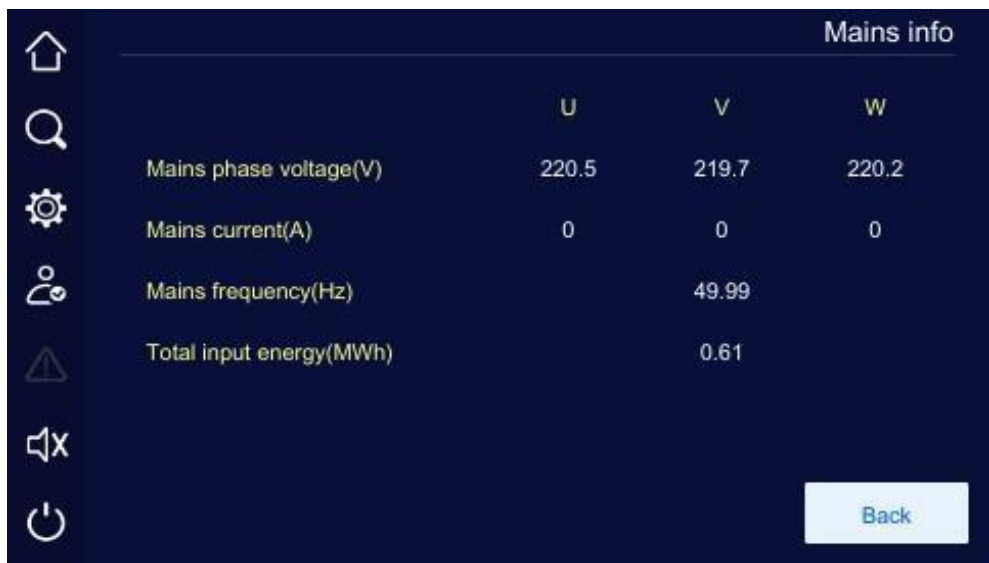



Figure4-13 Mains information

4.5.2 Bypass Input Information

In main page, click  icon, it will enter the bypass information page, as shown in Figure4-14. In the page, it shows the bypass phase voltage, bypass current and bypass frequency.

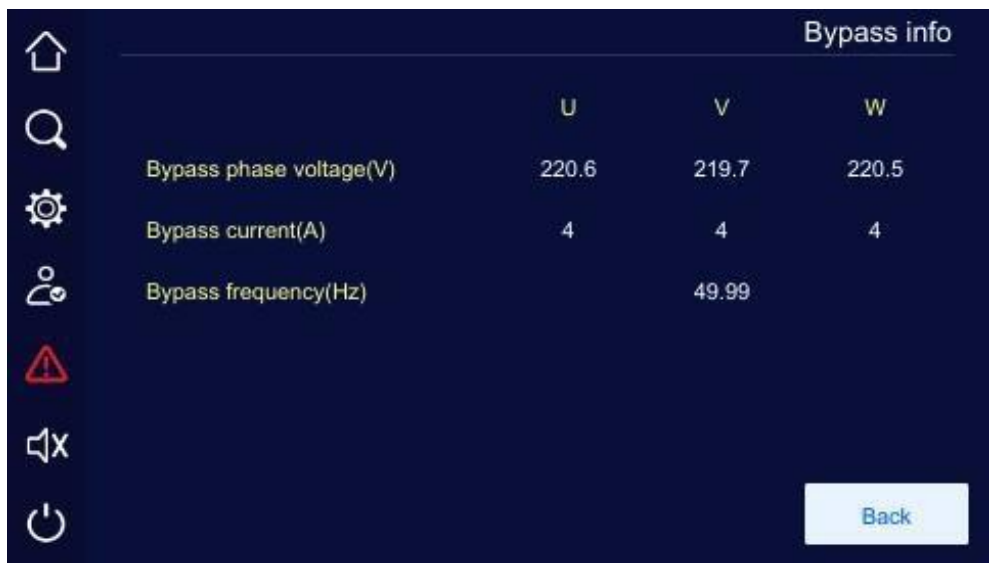



Figure4-14 Bypass information

4.5.3 Battery Input Information

In main page, click  icon, it will enter the battery information page. If the battery is lead-acid cell, it shows the positive and negative battery group voltage, battery charge/discharge current, battery remaining capacity, battery remaining time, battery temperature, battery status. It shows the

charging current or discharging current according to battery charge/discharge status, as shown in Figure4-15.



Figure4-15 Battery information

4.5.4 Rectifier Information

In main page, click  icon, it will enter the rectifier information page, as shown in Figure4-16. In the page, it shows the input phase voltage, input current, input frequency, battery voltage, charge current, discharge current.



Figure4-16 Rectifier information

4.5.5 Inverter Information

In main page, click  icon, it will enter inverter information page, as shown in Figure4-17.



Figure4-17 Inverter information

4.5.6 Output Information



In main page, click  icon, it will enter the output information page, as shown in Figure4-18. In the page, it shows the current output phase voltage, output line voltage, output current, output active power, output apparent power, output load rate, output power factor, output frequency and total output electricity.



Figure4-18 Output information

4.6 Setting Manage

In main page, click  icon, it will enter the setting manage page, as shown in Figure4-19. In the page, it shows cabinet setting, battery setting, battery test, output setting, smart mode, dry contact, screen setting, password setting, comm. setting and record manage.

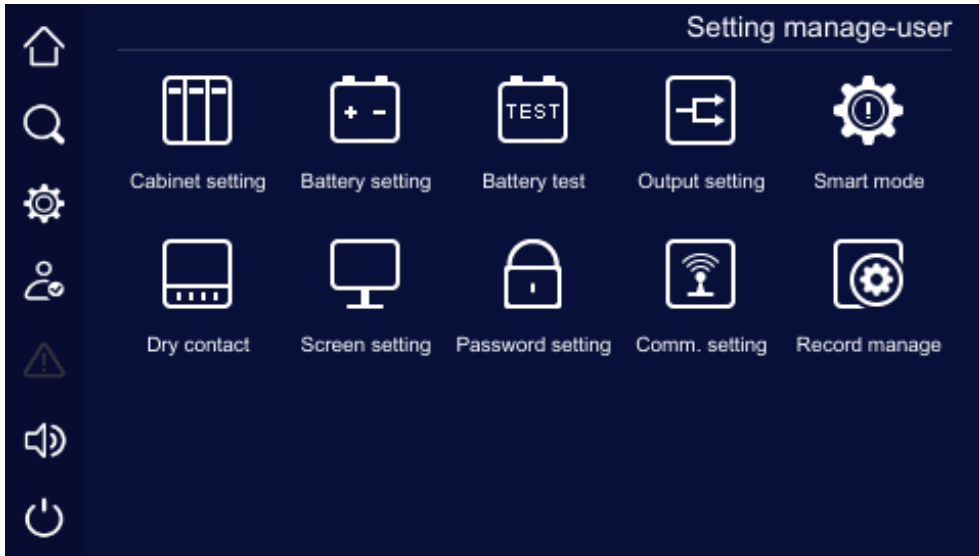



Figure4-19 Setting manage

4.6.1 Cabinet Setting

In set manage page, click  icon, it will enter the cabinet setting page, as shown in Figure4-20.

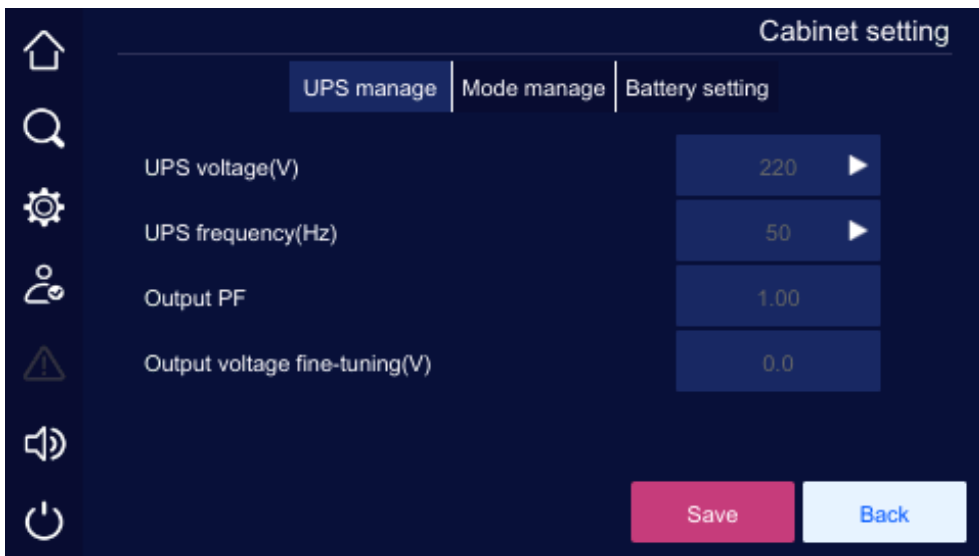

Figure4-20 Cabinet setting

4.6.2 Battery Setting

In set manage page, click  icon, it will enter the battery setting page, as shown in Figure4-21.



Figure4-21 Battery setting

4.6.3 Battery Test

In set manage page, click  icon, it will enter the battery test page, as shown in Figure4-22.

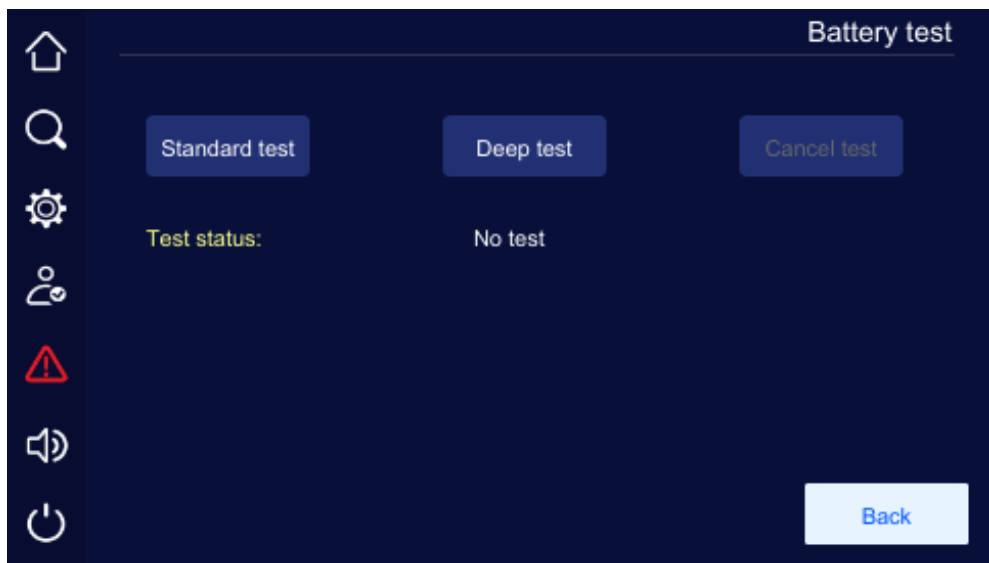

Figure4-22 Battery test

4.6.4 Output Setting



In set manage page, click  icon, it will enter the output setting page, as shown in Figure4-23.



Figure4-23 Output setting

4.6.5 Smart Mode

In set manage page, click  icon, it will enter the smart mode page, as shown in Figure4-24.

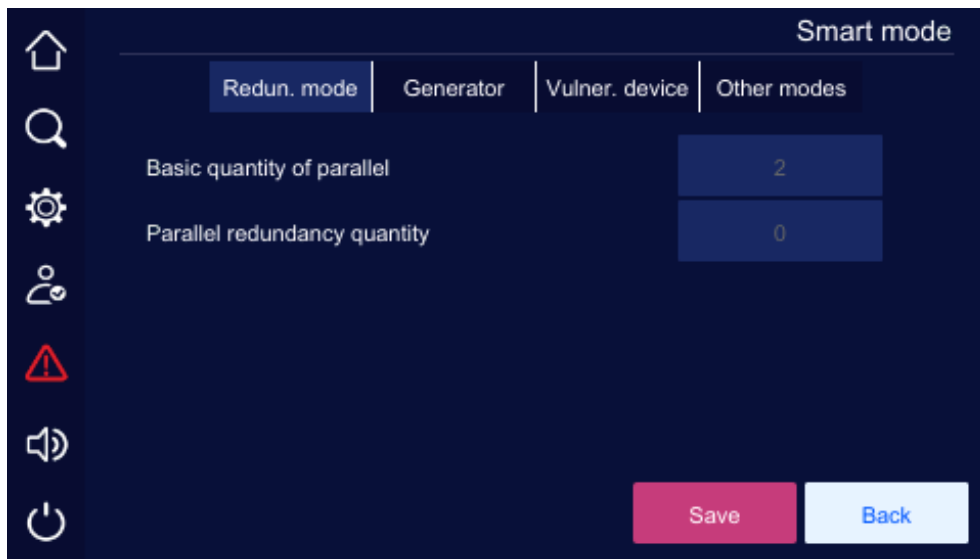



Figure4-24 Smart mode

4.6.6 Dry Contact

In set manage page, click  icon, it will enter the dry contact page, as shown in Figure4-25.

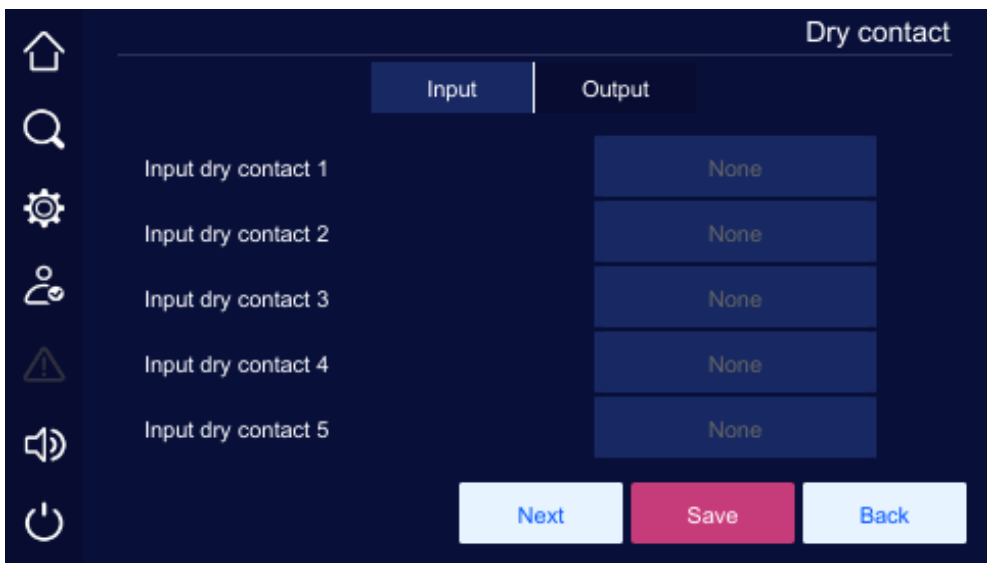



Figure4-25 Dry contact

4.6.7 Screen Setting

In set manage page, click  icon, it will enter the screen setting page, as shown in Figure4-26.

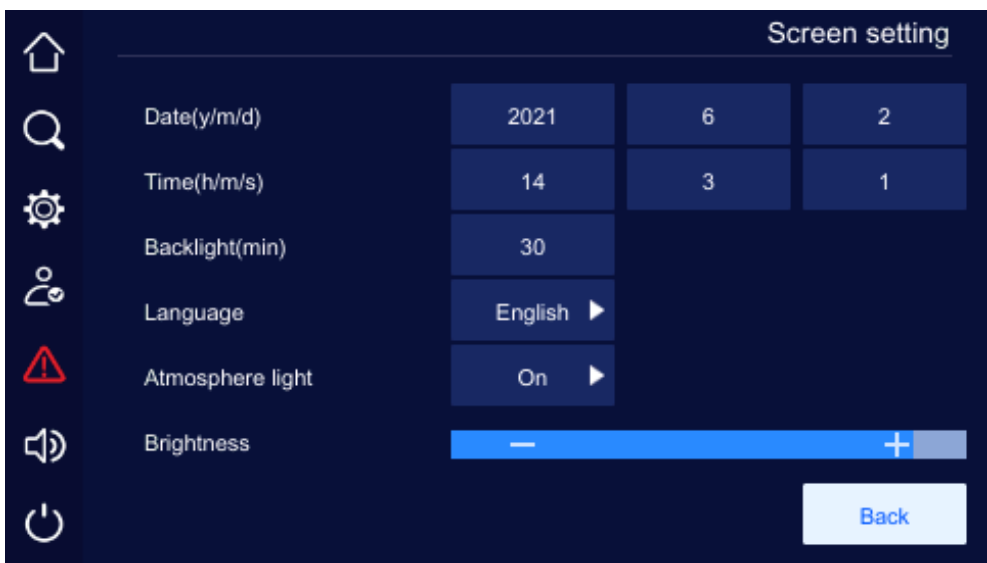



Figure4-26 Screen setting

4.6.8 Password Setting

In set manage page, click  icon, it will the password setting page, as shown in Figure4-27.

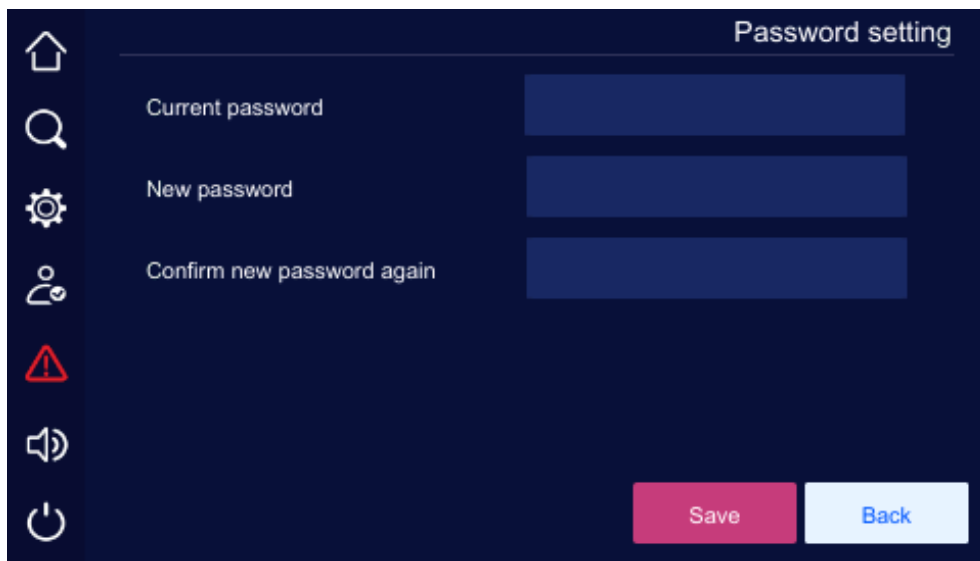



Figure4-27 Password setting

4.6.9 Communication Setting

In set manage page, click  icon, it will enter the communication setting page, as shown in Figure4-28.

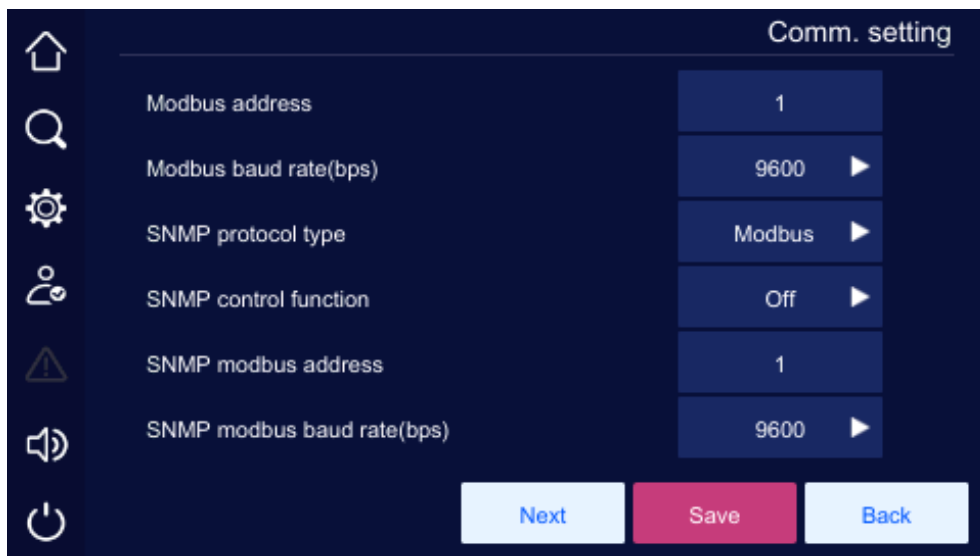



Figure4-28 Communication setting

4.6.10 Record Manage

In set manage page, click  icon, it will enter the record manage page, as shown in Figure4-29.

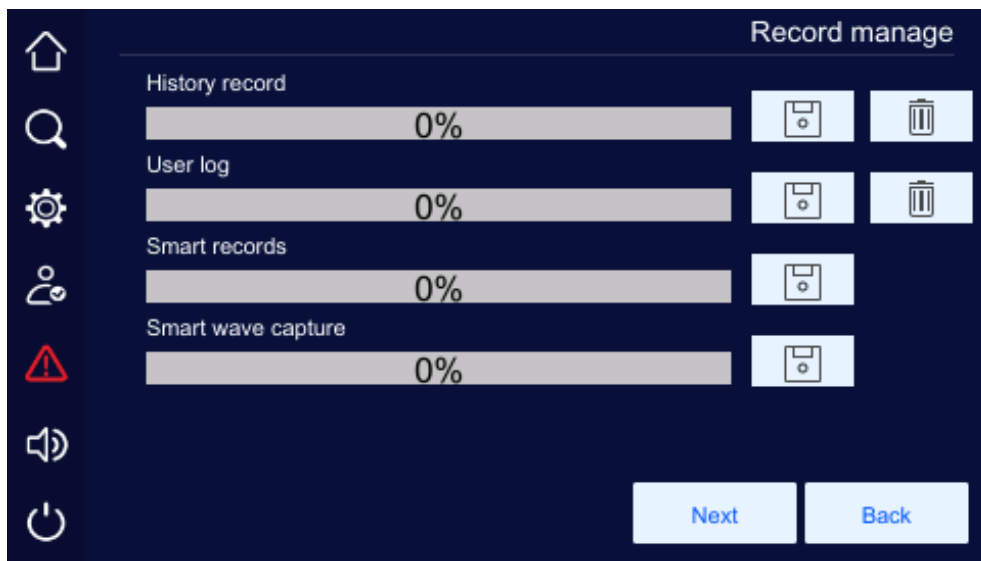



Figure4-29 Record manage

4.7 Information Manage

In main page, click  icon, it will enter the information manage page, as shown inFigure4-30.

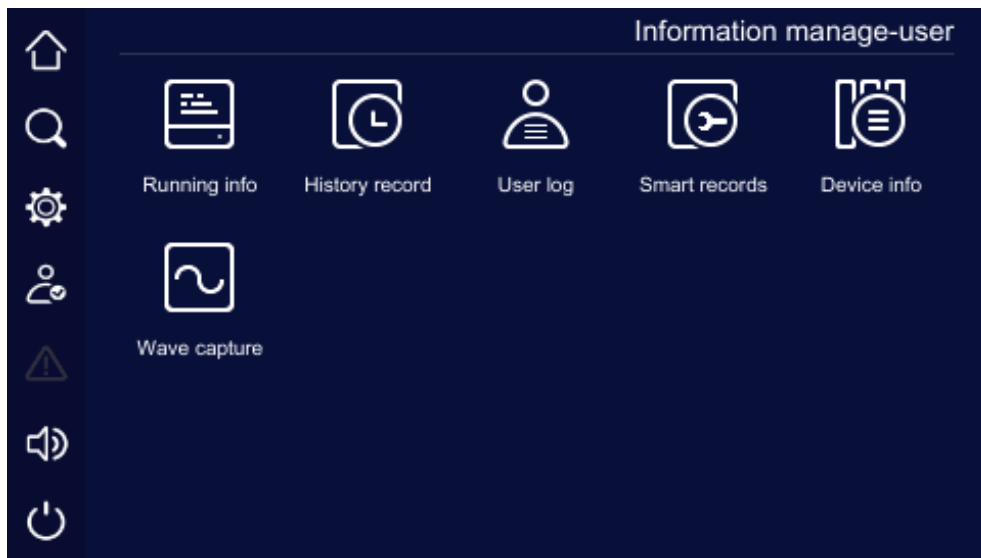



Figure4-30 Information manage

4.7.1 Run Information

In information manage page, click  icon, it will enter the run information page, as shown in Figure4-31.

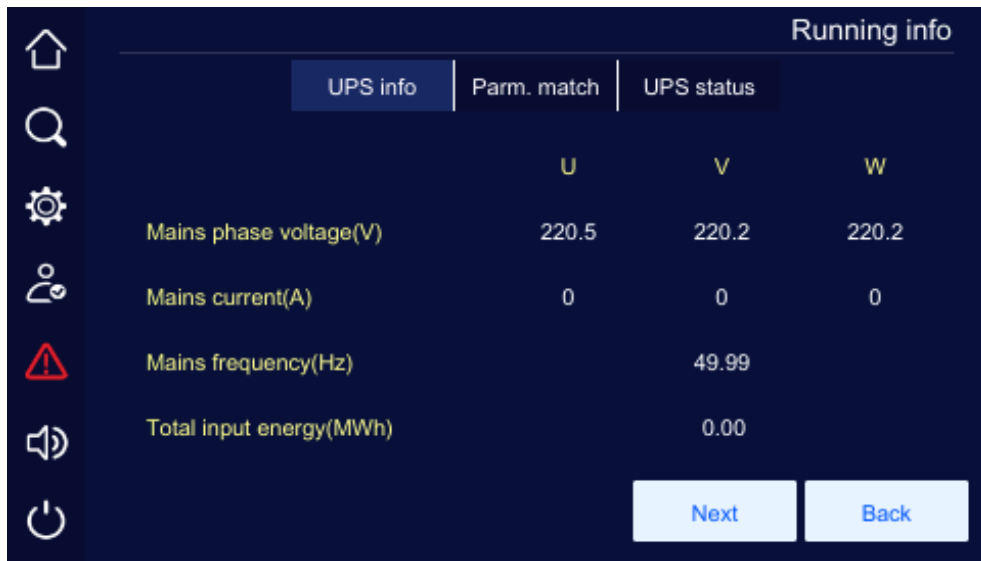



Figure4-31 Run information

4.7.2 History Record

In information manage page, click  icon, it will enter the history record page, as shown in Figure4-32. In the page, it shows the history fault and alarm information of system and unit.

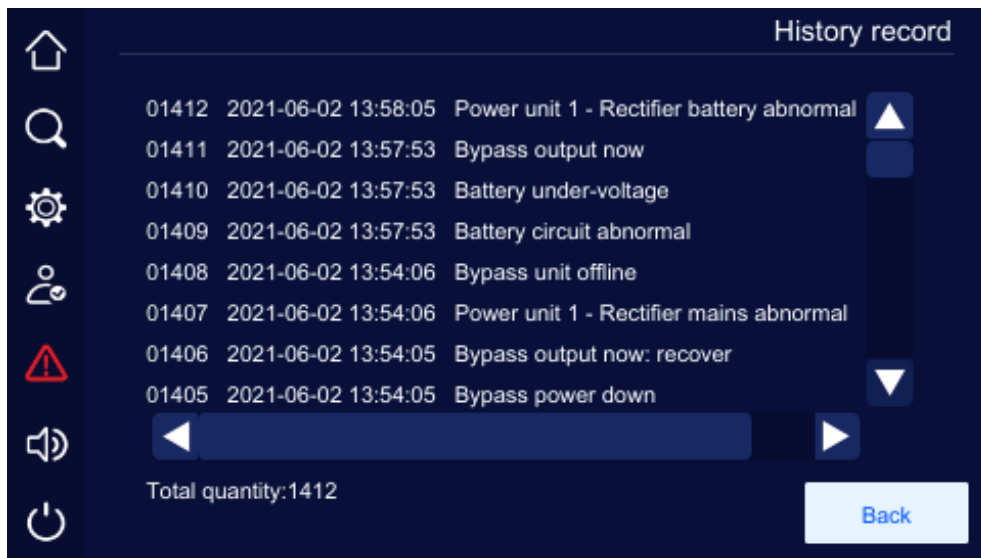

Figure4-32 History record



CAUTION

It can record 10000 pieces information at most. When the record exceeds 10000 pieces, the earliest information will be covered by new one. All records are ranked in reverse order of time.

4.7.3 User Log

In information manage page, click  icon, it will enter the user log page, as shown in Figure4-33. In the page, it shows the user parameter setting record.



Figure4-33 User log



CAUTION

It can record 10000 pieces information at most. When the record exceeds 10000 pieces, the earliest information will be covered by new one. All records are ranked in reverse order of time.

4.7.4 Smart Record



In information manage page, click  icon, it will enter the smart record page, as shown in Figure4-34



Figure4-34 Smart record

4.7.5 Smart Wave Capture

In information manage page, click  icon, it will enter the smart wave capture page, as shown in Figure4-35.

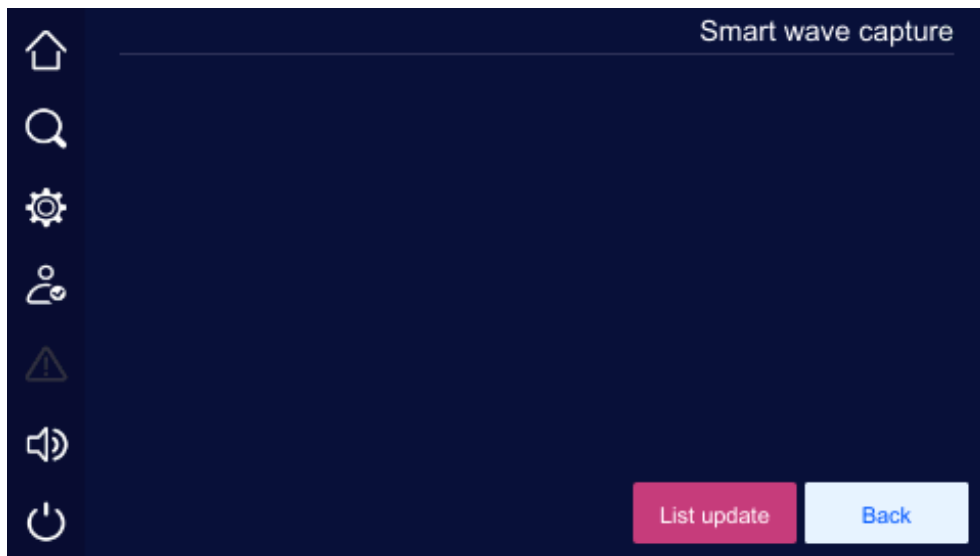

Figure4-35 Smart wave capture

4.7.6 Device Information

In information manage page, click  icon, it will enter the device information page. In the page, it shows the product name, model, S/N, product version, status, etc, as shown in Figure4-36,

Figure4-37, Figure4-38, Figure4-39.

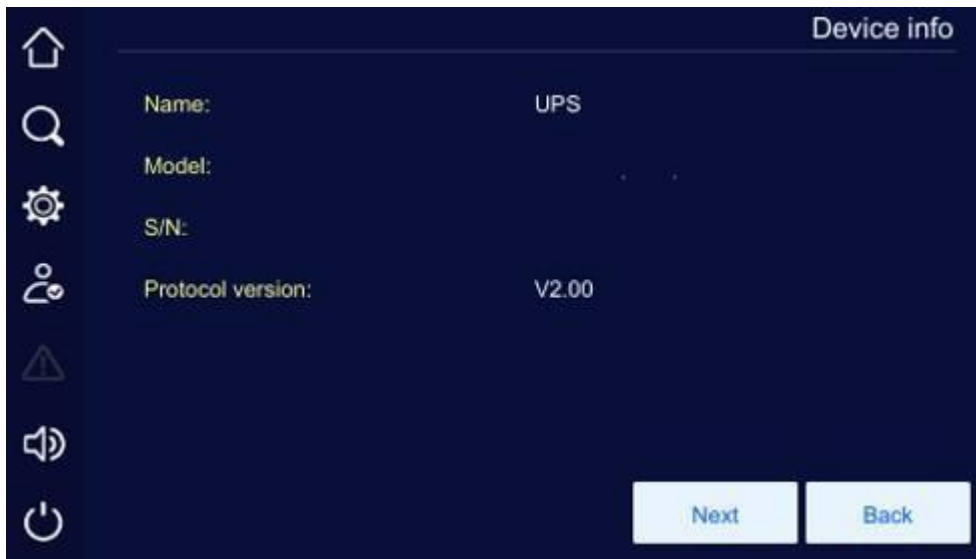

Figure4-36 Product information 1

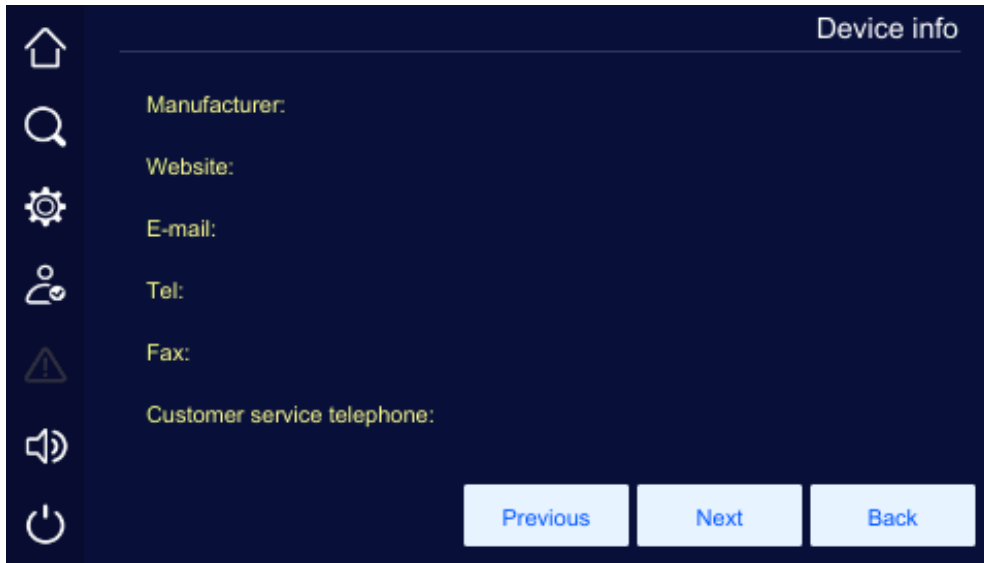

Figure4-37 Product information 2

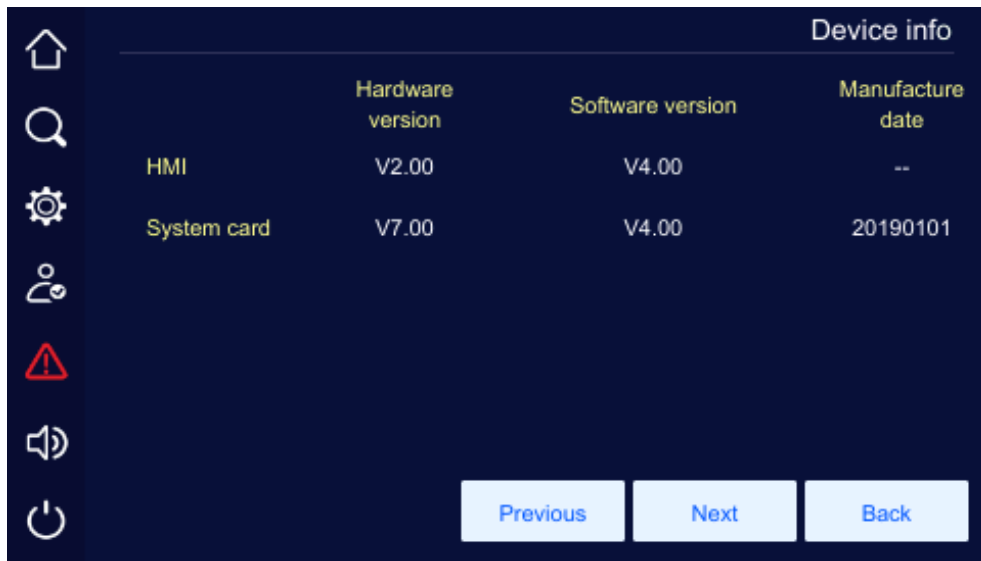



Figure4-38 Product information 3



Figure4-39 Product information 4

4.8 ON/OFF

In main page, click  icon, it will enter the ON/OFF page. When the system is OFF, click the icon to enter the confirm page, as shown in Figure4-40. Click **Confirm** button to perform the startup operation.

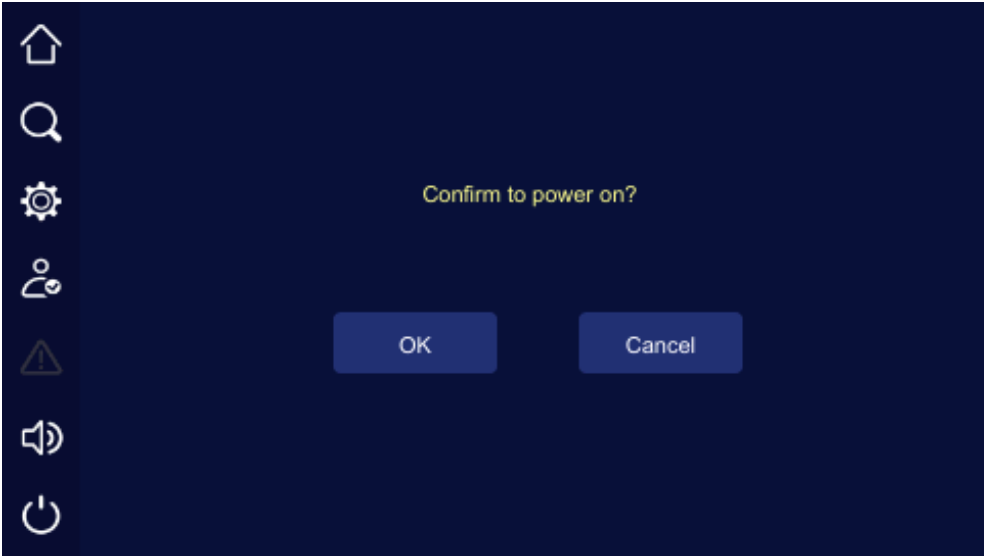

Figure4-40 Power on prompting

5 Use and Operation

This chapter mainly introduces the operation procedure and method, including using announcements, operation procedure, UPS start and parallel system start, etc.

5.1 Use Announcements

- Before starting the UPS, check whether the load is proper. The load must not exceed the rated output power of the UPS, which is to avoid overload protection.
- Do not use the <ON> and <OFF> buttons on the UPS panel as the power supply switches of load. Do not start the UPS frequently.
- After the UPS works stably, turn on the load. Some devices has large starting current which may cause overload protection, it is better to start these devices first. Start large power device first, then small power device. If you want to turn off UPS, it must turn off load first.
- When mains power outage, if the UPS is power supplied by generator, it is necessary to start the generator firstly. After the generator works stably, the UPS can be connected, or it may cause UPS or load damage.
- When output have transducer, it is only suited for transducer the capacity of output power within 1.5 multiples, if exceed the specification, result in the device cannot normally work.

5.2 Operation Procedure

Before first start the UPS, it is necessary to do the check, see section 5.3.1 . Only pass the examination, then you can power on the UPS. If the UPS won't be used for a long time, it also needs to be checked before startup. Operation procedure is as shown in Figure5-1.

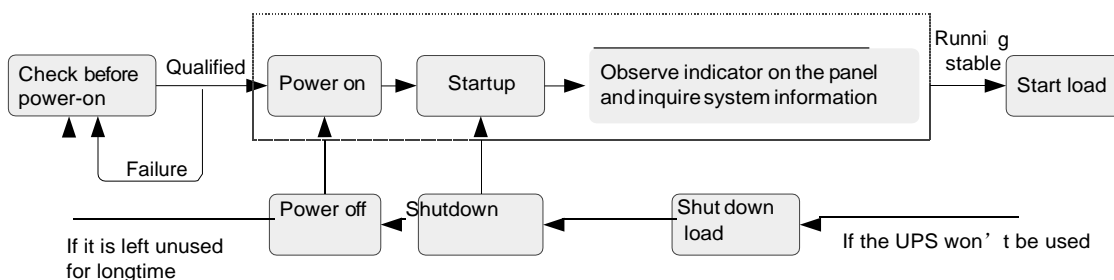

Figure5-1 Operation procedure

5.3 UPS Start and Shutdown

5.3.1 Check before Startup

Before startup, check according to following steps. Only when the check is OK, then the UPS can be started.

Step 1 Ensure that the mains switch (POWER), bypass switch (BYPASS), output switch (OUTPUT), maintenance bypass switch (MAINTENANCE) are all OFF.

Step 2 Check load.

- Ensure that the load is not conductive load. The output of the UPS cannot be conductive load, such as motor, fan, air-condition, etc. Generally, these loads are power supplied by power-grid.
- Ensure that the load is close. And at the same time, the load capacity should not exceed the UPS rated output capacity, or, it will cause overload protection.

Step 3 Ensure that there is no short-circuit between the live wire and neutral wire, live wire and grounding wire of input and output.

Step 4 Measure the AC voltage of mains input terminal (POWER), and the voltage should be within the range of 160V-280V, or, it can be started from battery status only.

Step 5 Measure the DC voltage of battery input. The voltage of positive battery group should be greater than a certain value(+11.5× battery amount), the voltage of negative battery group should be less than a certain value(-11.5× battery amount), and pay attention to the polarity, avoid wrong battery connection.

Step 6 Ensure that the auxiliary contact of battery switch is connected to the any input dry contact of bypass unit and set the corresponding info in touch screen.

----End

5.3.2 UPS Startup

Step 1 Recheck all the system parameters setting in **5.3.1 Check before Startup** is right.

Step 2 Close the "Limit switch" of all power unit

Step 3 Switch on the bypass switch → mains switch → external battery switch, it will in bypass power supply mode. (If it is battery cool start, only just switches on the external battery switch, and then press the battery cold start button on the bypass unit for more than 3s, the system power is set up).

Step 4 Start the inverter.

- Startup method 1: ON combination button on the panel

When the green indicators of all power units slowly flicker, press ON combination button on the panel for 3s to perform the startup operation.

- Startup method 2: Touch screen

In main page of touch screen, click  icon, it will enter the ON/OFF page, as shown in Figure5-2, click **Confirm** button to perform the startup operation.



Figure5-2 Power on prompting

Step 5 After start the inverter, UPS turns to inverter to supply power. User can view the system running status chart and ensure if the system turns to inverter to supply power. During testing, ensure that the UPS three-phase output voltage and frequency is normal through the real-time data in the touch screen.

Step 6 Switch on the output switch, check if the output voltage and output frequency of UPS are normal by multimeter. If yes, UPS can be used.

Step 7 Start the load. Generally, start large power device first, then small power device.

----End

5.3.3 UPS Shutdown



CAUTION

When the system bypass is normal, after the UPS shutdown, system will turn to bypass power supply mode; when system bypass is abnormal, after the UPS shutdown, system will be without output. Before shutting down, please ensure that the load is closed and support the UPS power off at any time.

Step 1 Close the user load.

Step 2 Shut down the inverter.

- Shutdown method 1: OFF combination button on the panel

Press the panel OFF combination button on the panel for 3s, the system will turn to the bypass output from inverter output. View the system running status in the touch screen to check if the system turns to the bypass power supply mode.

- Shutdown method 2: Touch screen

In main page, click  icon, it will enter the ON/OFF page, as shown in Figure5-3, click **Confirm** button to perform the shutdown operation.

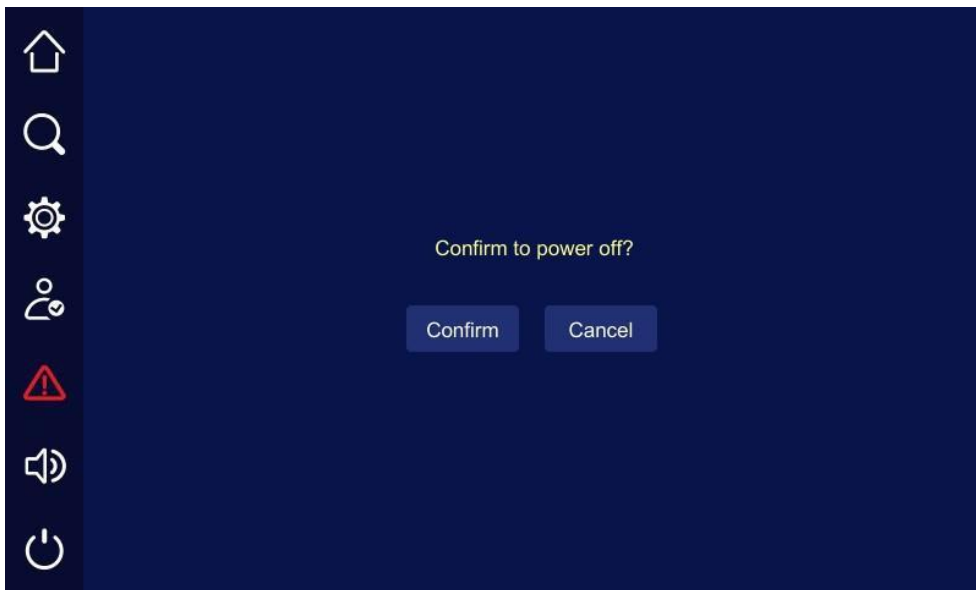

Figure5-3 Power off prompting

Step 3 Switch off the external battery switch → mains switch → bypass switch → output switch.

Step 4 After the touch screen and all LED indicators are off, the UPS is completely shut down.

----End

5.3.4 Switch to Bypass Mode Manually



CAUTION

Before shutting down the inverter of UPS, please ensure that the bypass is normal. When bypass abnormal, after shutdown the inverter manually, the system will be with no output and the power supply for load will be interrupted.

Shut down the UPS inverter, please see Step 2 in **5.3.3 UPS Shutdown**. System will turn to bypass to supply power automatically.



NOTE

When the bypass input voltage or frequency exceeds the setting value, shutting down the inverter will cause system without output, and the power supply for load will be interrupted.

5.3.5 Switch to Maintenance Bypass Mode From Inverter Output



CAUTION

Unless professional person, no one can perform the following operation. Manufacturer does not take charge of the problem caused by the operation of untrained person.

Step 1 In system management page, click the ON/OFF icon, it will enter ON/OFF page, then click **Confirm** button to shut down device.



NOTE

The inverter also can be shut down by OFF combination button on the panel for 3 seconds, but generally, it is not suggested to operate like this.

Step 2 After switch to bypass and the energy flow on the touch screen shows bypass output, set the maintenance bypass switch to ON.

Step 3 Switch off the mains switch→external battery switch→bypass switch.

- Step 4 Switch off the output switch, after the touch screen and all LED indicators are all off, the maintenance can be done.

**CAUTION**

During maintenance, it is strictly forbidden to close the output switch (OUTPUT).

----End

5.3.6 Switch to Inverter Output from Maintenance Bypass

**CAUTION**

Before perform the operation of switching to inverter power supply from maintenance bypass, please ensure that the system bypass input is normal.

- Step 1 Switch on the bypass switch → mains switch → external battery switch → output switch.
- Step 2 After the power is normal and the energy flow on touch screen shows bypass output, set the maintenance bypass switch to OFF. At this time, the bypass supplies power for load.
- Step 3 Start the inverter.

When the green indicator of all power units slowly flicker, enter the ON/OFF page by the touch screen, select ON/OFF icon then click **Confirm** button to start inverter. The UPS turns to inverter output.

**NOTE**

The inverter also can be started by ON button on the panel for 3 seconds, but generally, it is not suggested to operate like this.

----End

5.3.7 Emergency Power Off(EPO)



CAUTION

Do not perform the EPO operation unless emergency.

Press the external EPO button of system, the UPS will turn to emergency stop status. At this time, the touch screen shows EPO protection and the buzzer long beeps.



CAUTION

1. EPO function is optional.
 2. After pressing the **EPO** button, the UPS is with no output, the power supply for load is interrupted.
 3. When the system stay in maintenance bypass status, after pressing EPO button, the UPS still has output.
-

5.3.8 Emergency Power Off Recovery

- Step 1 Ensure that the dry contact of bypass unit, which connected to the external EPO switch, is not in emergency power off status.
- Step 2 Disconnect the system mains input switch, output switch, bypass switch and battery switch, until all system indicators are off, system power down completely.
- Step 3 Close the mains switch (POWER), bypass switch (BYPASS), battery switch, system will be started again, and EPO removes.

----End

5.4 Parallel System Startup and Shutdown

5.4.1 Start Parallel System



CAUTION

- Before start the parallel system, please perform the operation of **5.3 UPS Start and Shutdown** for each UPS.
 - Before power on and test the parallel system, please ensure that the wire connection of input and out cables and phase sequence is right and the parallel wire is well connected and stay in disconnection status.
 - Before completely starting the parallel system, please do not start load, and ensure that all switches of load are off.
 - Before performing the parallel wire operation, please do not connect the parallel wire.
-

Step 1 Measure the front-end voltage and frequency of input switch of all UPSs(including mains switch and bypass switch) or external input distribution switch. Voltage range: 160V-280V, frequency range: 40Hz-70Hz.

Step 2 Connect the parallel wires, switch on the mains switch and bypass switch of all UPSs(keep the output switch of all UPSs on off status). If the input power is normal, the rectifier will start automatically, and the touch screens begin to start.

Step 3 Connect the battery to the parallel system.

Step 4 If the monitor page of each UPS has no alarm, switch on the battery switch of each UPS(if there are many groups of batteries, it needs to switch off the switch of each battery group, and then switch off the total switch between UPS and battery groups). Measure the voltage of battery switch by multimeter(if there are many groups of batteries, measure the voltage of battery switch of each battery group, and then measure the voltage of total switch). Ensure that the battery connection is normal (the "Battery circuit abnormal" alarm on the main page of touch screen disappears within 2min).

Step 5 Check if the system alarms are all disappeared. If there is any fault alarm, please stop the startup operation and inform serviceman to solve the problem till all faults are removed.

Step 6 Start the inverter of each UPS. Ensure that each UPS stay in bypass power supply mode and the system has no alarm, start the inverter of each UPS manually, and all UPSs turn to invertermode.

Step 7 Measure the output voltage and output frequency of each UPS. After each UPS turns to inverter mode(view the system running status in the touch screen to check if the system is in the inverter power supply mode.), check if the output voltage and output frequency of UPS are normal through the real-time data in the touch screen, measure the front-end output voltage of output switch in output distribution cabinet or external output distribution switch to ensure that the inverter output voltage is normal(output voltage = output voltage setting $\pm 2V$), and ensure that the inverter output frequency is normal(output frequency = output frequency setting $\pm 0.1Hz$). Record the measured output voltage effective value of each UPS).

Step 8 Compare the output voltage of each UPS. After measuring the output voltage and frequency of each UPS, compares the output voltage of each UPS, ensure that the phase voltage effective value difference of any two UPSs is less than 5V, and then the parallel operation can be done. If it does not meet the requirement, the UPS with big voltage difference cannot be connected in parallel system, and it is necessary to debug again.

Step 9 Shut down the inverter of each UPS. Ensure that there is no alarm of each UPS, shut down each UPS manually. All UPSs turn to the bypass mode.

Step 10 Check the phase sequence of bypass.

Switch on the output switch of UPS 1(ensure that the total switch of load is switched off, or once switching on the output switch of UPS 1, it will supply power for load), keep output switches of other UPSs off, set the multimeter to AC position, one pen connects with the output switch front-end phase-A of UPS 2 and the other pen connects with the output switch back-end phase-A of UPS 2 to measure the voltage difference between the front-end and back-end of output switch of UPS 2. Measure the voltage difference of phase-B and phase-C as the same way. If the phase sequence is right, the voltage difference of each phase should be less than 5V. If the phase sequence is not right, at least one phase voltage difference is greater than 5V. Measure whether the bypass sequence of each paralleled UPS is right(When measuring the other UPSs' phase sequence, it doesn't need to operate the switch. Keep the output switch of UPS1 on and the output switches of other UPSs off). If all bypass phase sequence of all UPSs is right, go on next step. If the phase sequence of any UPS is not right, power off the system and check the input and output wiring of each UPS and see if the connection is right.

Step 11 Switch on the output switches of all UPSs.

Ensure that each UPS is with no alarm, switch on the output switches of all UPSs successively. Ensure that the output of all UPSs is in parallel status.

Step 12 Start the inverter of each UPS.

Ensure that the system is with no alarm, manually start the inverter of each UPS successively. System starts inverter output. Monitor that there is no alarm.

Step 13 Shutdown the inverter of each UPS.

Ensure that each UPS is with no alarm, shut down the inverters of all UPSs, the system turns to the bypass mode.

Step 14 Switch on the total output switch of load.

After the parallel system turns to the bypass power supply mode, switch on the total output switch of load, bypass supplies power for load.

Step 15 Start each UPS successively, the system will turn to the inverter mode.

----End

5.4.2 Shutdown Parallel System



CAUTION

If the system bypass is normal, after shutting down the UPS, the system will turn to bypass power supply mode; if the system bypass is abnormal, after shutting down the UPS, the system will turn to no output mode, the system output is outage. Before shutting down, please ensure that load is closed and can endure the status of power outage at any time.

Step 1 Close the load of parallel system, keep the UPS run without load to eliminate inner heat.

Step 2 Perform **5.3.3 UPS Shutdown** to close all UPS, system turns to bypass power supply.

Step 3 Disconnect the load total switch, each UPS output switch (OUTPUT), battery switch, bypass switch (BYPASS), mains switch (POWER) successively.

----End



NOTE

If it just needs to close the UPS, system turns to bypass power supply and the load without power outage, just perform Step 2; if it needs to power off all UPS system, perform all above steps.

5.4.3 Emergency Power Off (EPO)

Single UPS running

Press the EPO button of the UPS or the EPO button of total system, the UPS will shut down and close all output.

Multi UPS running in parallel system

- EPO linkage is enabled

Press the EPO button of the UPS or the EPO button of total system, all the paralleled UPS will shut down and close all output.

- EPO linkage is not enabled

Press EPO button of one UPS, the output of this UPS will be closed.

Press the EPO button of total system, all paralleled UPS will be shutdown and all output will be closed.

6 Maintenance and Troubleshooting

This chapter mainly introduces the UPS maintenance guide, battery daily maintenance, battery replacement announcement and troubleshooting, etc.

6.1 Maintenance Guide

Proper maintenance is the key to make the device operate in the best status and with a longer service life.

6.1.1 Safety Precautions

To ensure human safety and equipment security, observe the following precautions.

- Please keep in mind that there is dangerous voltage inside the UPS even if the UPS does not operate. Before maintenance, use a multi-meter to check the voltage and make sure that the UPS is completely shut down and stays in safe status.
- Before close the battery switch at any time, use a multi-meter to measure if the voltage of multi-meter is normal and the polarity is reverse connected. If the result is abnormal, it is strictly forbidden to close the battery switch.
- Do not wear any conductive metal objects during operation, such as ring, watch.
- Observe safety regulations strictly. If any doubt, consult professionals.

6.1.2 Preventive Maintenance

To improve the UPS reliability and efficacy, perform the following maintenance tasks on a quarterly basis.

- Keep the operating environment free from dust and chemical pollutants.
- Check if the wiring terminals on input, output cables are in good contact every half year.
- Check the fans work status periodically and avoid blocking the air vents. If a fan is damaged, maintain or replace it in time.
- Check the voltage of batteries periodically and ensure that the battery voltage is within the normal range.

- Check the UPS status periodically and ensure that any fault can be found in time.

6.2 Battery Maintenance

- Battery charge requirements
 - When first use the battery, please start the UPS and charge the battery for 24h. During charging, the UPS still can be used, but if power outage occurs at the same time, the battery discharge time may less than the standard value this time.
 - Generally, the battery needs to be charged and discharged every 4 to 6 months. First, discharge until 1/3 of battery capacity and then charge the battery. The charge time of each time cannot less than 24h.
 - In high temperature area, the battery needs to be charged and discharged every 2 months and the charge time of each time cannot less than 24h.
 - If the battery will not be used for long time, it also needs to charge the battery every 3 months and the charge time of each time cannot less than 24h.
- Clean battery shells by water-dipped cloth. Oil and organic solvents, such as petrol and diluents are prohibited.
- To avoid explosion, keep batteries far away from fire sources and devices that easily generate sparks.
- Avoid over-discharge the battery during using. Fully charge the battery immediately after discharge (24h at latest) and then the battery can discharge again. It is strictly forbidden to discharge the not fully charged battery, or, it will cause battery capacity decrease even damage battery.
- To avoid battery discharging for too much time after mains power outage, disconnect the battery switch when the UPS is not used.

6.3 Announcementsfor Battery Replacement

- Dangerous voltage may exist in the battery terminal and grounding terminal, before touching, please measure if there is dangerous high voltage, which is to avoid endanger human safety. It is strictly forbidden to touch the two wiring pillars or the bare end of battery.
- The battery should be replaced in whole group, do not use the new battery and old battery together.
- A new battery should be with the same capacity, model, and manufacturer as the replaced one. The battery with different capacity, different type and different manufacturer battery is strictly forbidden to use together.

- Recycle the battery according to the relative illustration on the battery.
- Do not put the battery into fire, which is to avoid explosion.
- Do not open or disassemble the battery, for the inner electrolyte is harmful for skin and eyes.

6.4 Troubleshooting

6.4.1 Common Abnormal Phenomena Diagnosis

If the UPS works abnormally after start, please refer to Table6-1 to find possible reason. Meanwhile, check whether the fault is caused by external environment, such as temperature, humidity is not accordance with the requirement or overload.

Table6-1only includes some simple diagnosis. If the diagnosis is not clear, or not sufficient to solve the problem, please contact with local agency or dealer to deal with.

Table6-1 Troubleshooting

NO	Abnormal phenomena	Possible reason
1	Mains normal, but UPS works in battery inverting status, the buzzer beeps intermittently.	Each connection point, socket of grid feed circuit is not so good, which causes the AC power supply input unblocked.
2	After installation, close switch or switch of power supply, it will fuse the fuse or trip off.	The three-phase input wires are wrongly connected, such as neutral wire and ground wire or live wire and grounding (case) is wrongly connected or the three-phase output wire is wrongly connected.
3	After startup, the UPS outputs 220V AC power, but the UPS works in bypass status.	<ol style="list-style-type: none"> 1. The load is too large and exceeds the rated output capacity of the UPS. It needs to reduce load or select a UPS with larger output capacity. 2. If it is temporary bypass caused by the impact of load startup, and it can recover to normal automatically, that is normal.

NO	Abnormal phenomena	Possible reason
4	The UPS output normally after startup, but once turn on load, the UPS stop outputting immediately.	<ol style="list-style-type: none"> 1. The UPS is serious overload or the output circuit is short-circuit. It is necessary to reduce load to proper capacity or find the reason of short-circuit. Common reason is output socket is short circuit or input short circuit caused by device damage. 2. The load is not started according to the sequence from large power device to small power device. You should restart the UPS. After the UPS run stably, start the load according to the sequence from large power device to small power device.
5	The UPS work normally after startup, but some time later, the UPS shut down automatically.	<p>At the status of battery supply power, the battery is runs out and system protects for battery under-voltage, the UPS shut down automatically. This phenomenon is normal. Once mains normal, system will start and charge battery automatically.</p> <p>Warning: if the battery stays in under-voltage status for long time, it will influence the battery service life. After battery under-voltage protection, if mains cannot recover in a long time, please disconnect the battery switch to protect battery and restart the UPS and fully charge the battery once mains recovers.</p>
6	After startup and work a period of time, buzzer long beeps and the touch screen shows battery low-voltage.	The mains voltage is too low, and the UPS works in battery inverting status, finally, the battery is under-voltage and causes under-voltage protection.
7	When there is mains, the UPS output normally, when there is no mains, the UPS is with no output.	<ol style="list-style-type: none"> 1. Battery fault or the battery group is serious damaged. 2. Charger fault. The battery cannot be charged and causes battery energy insufficient. 3. Battery wire is not well connected or the contact of wire terminal is not good. 4. Battery switch is not closed. 5. After serious overload of UPS, the UPS is not restarted, which causes the UPS stay in bypass output status.

NO	Abnormal phenomena	Possible reason
8	Buzzer long beeps, DC/AC indicator on, the UPS turns to bypass to supply power.	See the fault information on touch screen.
9	There is mains, but buzzer beeps intermittently.	The voltage or frequency of mains exceed the allowable range of the UPS.
10	At mains status, the UPS works normally, once power outage, the UPS works normally but load system halt.	The grounding is not so good and the float voltage between neutral wire and grounding wire is too large.
11	FAULT indicator of a power unit is on.	The power unit is fault, replace it in time.

6.4.2 Emergency Dispose for System Fault

1. How to deal with the system fault in emergency

When system fault, shut down the power supply of UPS by the touch screen, if necessary, close the user load and disconnect the input and output switch of the UPS to avoid further damage for the UPS. Inform the engineering technician to maintain.

2. How to deal with the fault of single power unit in emergency

When some power unit fault, it will be insulated with system automatically, and generally, it will not influence the system normal operation, but it will decrease the redundancy degree of the unit. At this time, please shut down the fault unit and pull it out of the cabinet, and then inform the engineering technician to maintain.

After pulling out the unit, there still has high voltage inside the unit and on the rear connector pin. It is necessary to wait enough time ($\geq 10\text{min}$) and then open the cover to maintain.

7 Package, Transportation and Storage

This chapter mainly introduces the package, transportation and storage of the UPS.

7.1 Package

During packing, please pay attention to the place direction requirements. At the side of the package, there is afraid of wet, handle with care, upward, stack layer limit, etc. alarm marks. And also, the device model is pasted on the package. At front of the package, the LOGO of our company and device name is printed.

7.2 Transportation

During transporting, pay attention to the alarm marks and avoid severe impact on the device. Place the device according to the marked direction, which is to avoid damage the component. Any inflammable, explosive, corrosive object is not allowed to shipping with the device. While midway transportation, do not put the device in the open air. The device cannot suffer any rain, snow or liquid material or mechanical damage.

7.3 Storage

When storing the device, place the device according to the marked direction. The package box should be far away from ground for 200mm, and keep at least 500mm from wall, eat source, cold source, window or air inlet.

Storage temperature: $-20\sim 55^{\circ}\text{C}$. If the device is transported or stored out of the storage temperature, before installation and startup, put the device aside and let the device temperature recover to normal range for more than 4h. In the warehouse, any inflammable, explosive, corrosive object or harmful gas is not allowed, and also, strong mechanical shake, impact or magnetic field is forbidden. The storage period of these requirements, generally, is 6 months. If the device stored more than 6 months, it is necessary to check again. If the device is stored for a long time, please charge the battery every 3 months.

A Technical Specifications

Index		Model	120K	
Input	Input mode	3 ϕ 4W+PE		
	Rated input voltage (VAC)	220/230/240 (phase voltage)		
	Input voltage range	Vin=187Vac~280Vac, do not decrease rated power to use. Vin=80Vac~186Vac, linear decrease rated power to use.		
	Input frequency range (Hz)	40~70		
	Bypass synchronization tracking range (Hz)	50/60 \pm 6		
	Bypass input voltage	220/230/240 (phase voltage)		
	Input power factor	\geq 0.99		
	Input THDI	Full load: \leq 3%		
	Battery (VDC)	\pm 216		
	Charge current (A)	30	60	
Output	Output mode	3 ϕ 4W+PE		
	Output wave	Sine-wave		
	Voltage (Vac)	L—N: 220/230/240 L—L: 380/400/415		

Model		120K	
Index			
Frequency (Hz)		When mains normal, it tracks the bypass input; When mains abnormal, it tracks the frequency of the UPS in the range of 50 ± 0.1 or 60 ± 0.1 .	
Three-phase phase error		With three-phase rated balance resistive load $\leq 1^\circ$	
Wave form distortion (THDv)		Linear load $\leq 1\%$; non-linear load $\leq 4\%$	
Bypass inversion switch time		Synchronization $< 1\text{ms}$; Unsync: $< 15\text{ms}$	
Higher efficiency		96.5%	
Overload capacity	Linear load inverter overload capacity	$\leq 105\%$: long-term running; $105\% < \text{load} \leq 110\%$: 60min; $110\% < \text{load} \leq 125\%$: 10min; $> 125\%$: protect immediately	

Index		Model	120K
		Bypass overload capacity	<p> $\leq 130\%$: long-term running; $130\% < \text{load} \leq 150\%$: 5min; $150\% < \text{load} \leq 200\%$: 1s; $200\% < \text{load} \leq 300\%$: 100ms; $> 300\%$: protect immediately. </p>
		Current-equalized precision	$\leq 5\%$
		Output DC component	-200mV~+200mV
		Dynamic response transient range	When the load changes in the range of 0%~100% or 100%~0%, the output voltage transient range $\leq 5\%$
		Load unbalance capacity	Can bear 100% unbalance load
		Manual maintenance bypass	It equips the maintenance bypass switch without switch time.
		DC start function	Equipped
		Touch screen display	Three-phase input voltage, input frequency, three-phase output voltage, load, battery voltage, battery charge & discharge current, each unit output current and inner temperature, parameter setting, history record, etc.
		LED display	Work status and fault indication of UPS.
		Alarm function	Input abnormal, battery low-voltage, overload, fault
		Communication function	Provides dry contact communication and RS485, and it can also equip with SNMP to realize the smart monitor for the UPS.

Index		Model	60K				
	Protection function	Protect for output short-circuit, output over-voltage/ under-voltage, overload, over-temperature, battery under-voltage, comm. abnormal, etc.					
	EMC	Meet the provision of IEC 62040-2:2016					
	Noise (dB)	<65(measured away from the front cabinet for 1m)					
	IP protection class	IP20					
	Cooling way	Forced wind-cooling					
	Work temperature (°C)	-5~40					
	Wiring method	Bottom wiring					
	Size (W×D×H) (mm)	400*960*1200					
	Weight (kg)	163					

- Specifications are subject to change without prior notice.

B Acronyms and Abbreviations

A

AC Alternating Current

D

DC Direct Current

DSP Digital Signal Processor

E

ECO Energy Control Operation

EPO Emergency Power Off

I

IEC International Electrotechnical Commission

L

LCD Liquid Crystal Display

LED Light-emitting Diode

P**PE** Protective Earthing**R****RS232** Recommend Standard232**RS485** Recommend Standard485**S****SNMP** Simple Network Management Protocol**T****THD_v** Total Harmonic Distortion of output voltage**U****UPS** Uninterruptible Power System



MEDALPOWER

Leave Power for Medal Power

www.medal-power.com

